

1 3/4" ROLLED EDGE FRONT & ENDS PLAN VIEW

GENERAL SPECIFICATIONS

- * 16 GAUGE 304 STAINLESS STEEL FABRICATION
- * FULLY WELDED, SEAMLESS & POLISHED TO A UNIFORM FINISH
- * HORIZONTAL & VERTICAL CORNERS COVERED TO A 3/4" RADIUS
- * DIE FORMED DEPRESSION TO DRAIN IN BOWL BOTTOM
- * ONE-PIECE STAINLESS STEEL FRONT PANEL
- * 3" HIGH X 1 3/4" ROLLED RIMS WITH RADIUSED FRONT CORNERS
- * PITCHED DRAIN BOARDS

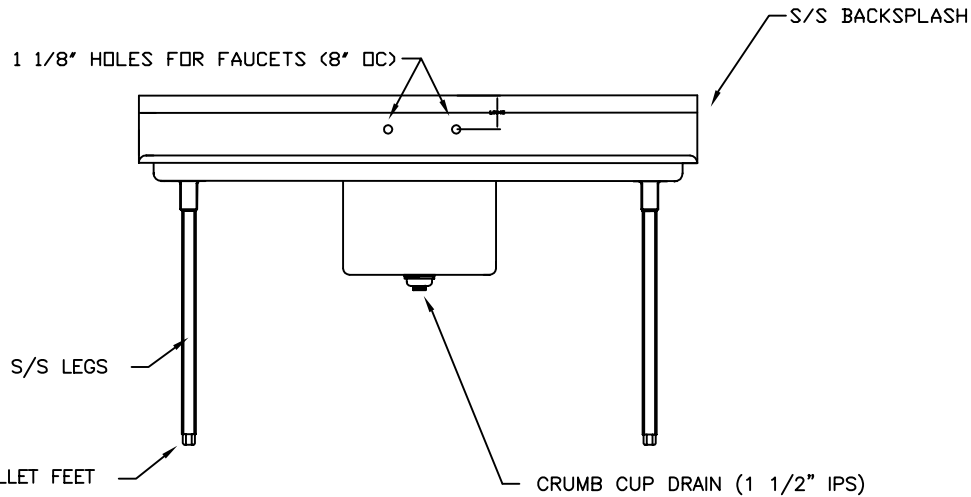

FRONT ELEVATION

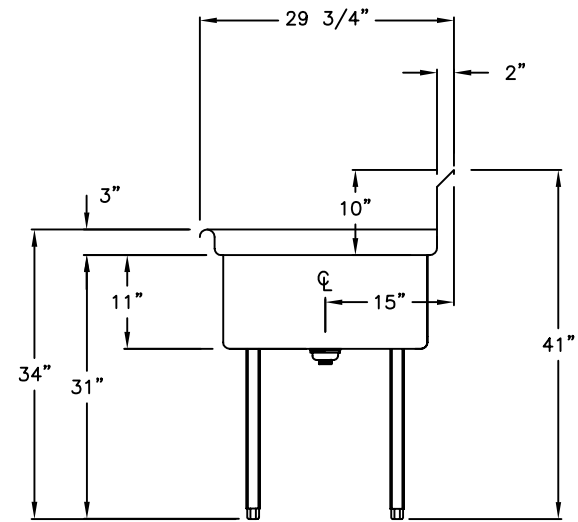

SECTION



MODEL #C-1-1824-24D STAINLESS STEEL SINK		
DRN BY	CHJ/AC	DWG.# C-1-1824-24D
DATE	9.16.02	
SCALE		