

NEW

Receiving Station and Shelving Built to Take a Beating.



Shown is Freestanding Computer
Receiving Station MCRS-33

Amtekco

I N D U S T R I E S I N C .

MANUFACTURERS OF QUALITY PRODUCTS
FOR THE FOOD MARKETING INDUSTRY

1205 Refugee Road • Columbus, Ohio 43207
800-336-4677 or 614-228-6590 • Fax: 614-737-8017
www.amtekco.com

Receiving Station and Shelving Built to Take a Beating.

Features/Benefits:

Receiving Station

- Durable fully welded stainless steel construction
- Heavy-duty hardware for years of dependable use
- Highly functional and adaptable
- Handy paperwork areas, drawer and cabinet spaces keep the busiest of backrooms organized
- Lift-up door protects and conceals upper paperwork storage area
- Pull-out keyboard and adjustable printer shelf, in addition to cabinet cooling fans and vents, enable convenient and safe PC setup
- 20" centered pull-out printer shelf in cabinet
- Backside grommets allow for easy PC wiring
- Clipboard rod keeps workers from losing clipboards
- 1/2" tall retaining edge on desktop keeps papers in place
- Slanted desktop for ergonomically correct posture
- Quality 5" locking casters allow for easy repositioning
- Front locking drawer
- Radiused desktop edge
- Hinged access doors to cabinet base
- Custom features available

Shelving:

- Heavy-duty 16 gauge stainless steel construction
- Solid, perforated or wire shelves available
- Adjustable shelf height and angle
- Wall support can be surface-mounted or concealed
- Works perfectly with the receiving station or as a stand-alone shelving unit
- Custom features available

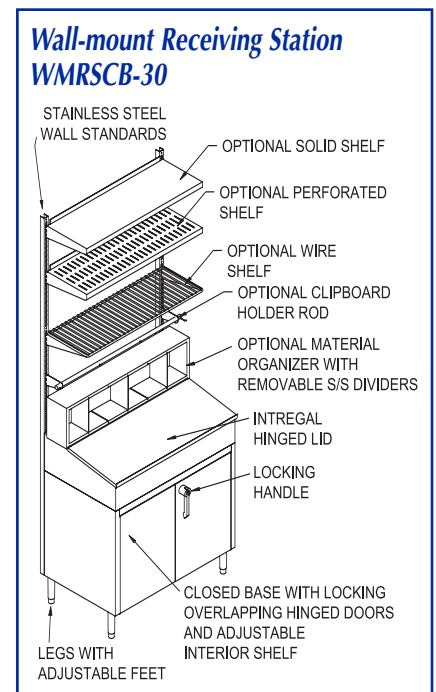
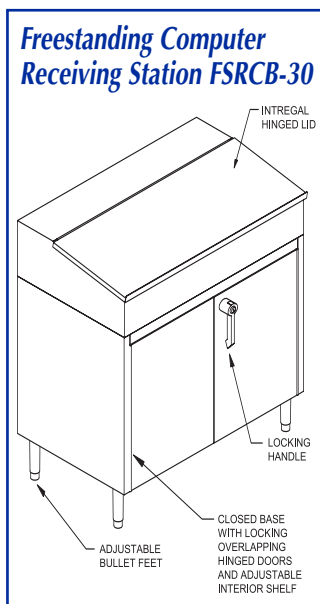
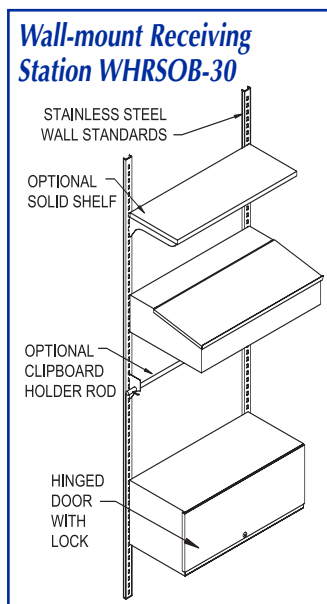
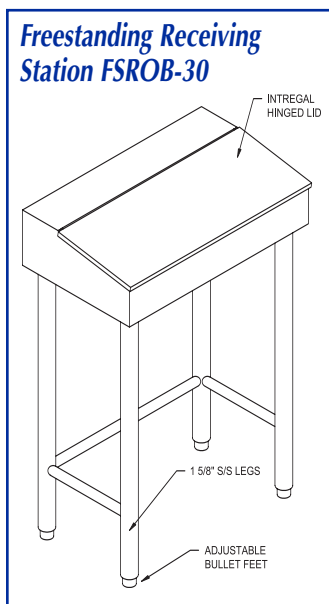

Contact your Amtekco sales representative: 1-800-336-4677

Amtekco
INDUSTRIES INC.

MANUFACTURERS OF QUALITY PRODUCTS
FOR THE FOOD MARKETING INDUSTRY

Equipment That Means Business

1205 Refugee Road • Columbus, Ohio 43207 • 800-336-4677 • 614-228-6590 • 614-737-8017 (fax) • www.amtekco.com