

Hot and Cold Combination Island



amtekco



A Wasserstrom Company

Manufacturers of Quality Products for the Food Marketing Industry

1205 Refugee Road • Columbus, Ohio 43207
800-336-4677 or 614-228-6590 • Fax: 614-737-8017
www.amtekco.com

Hot and Cold Combination Island

MODEL #	CASE LENGTH	CASE SECTION	REFRIG. CAPACITY BTUH	ELECTRICAL SPECS		
				Circuit	VOLTS	AMPS
HCCI-59R	59"	REFRIGERATED SECTION	6420 @+20°	1	120/208-1PH	1.28
		HEATED SECTION		2	120/208-1PH	20.3
HCCI-59SC	59"	REFRIGERATED SECTION	N/A	1	120/208-1PH	15.9
		HEATED SECTION		2	120/208-1PH	20.3

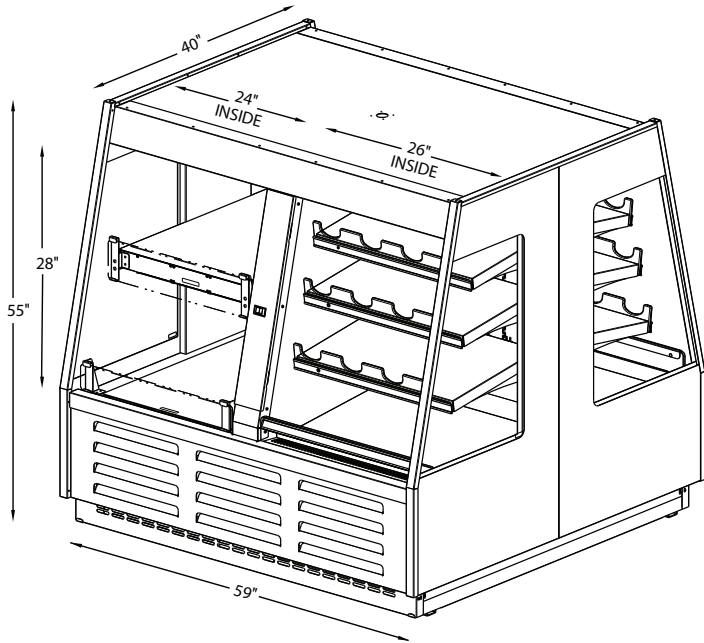

Standard features:

- Durable powder coated exterior finish
- Durable stainless steel interior finish
- End panels skinned and capped with powder coated metal for durability
- Energy efficient ECM evaporator fan motors
- T-8 energy efficient lighting (refrigerated section only)
- Thermal pane end glass for maximum product visibility and energy efficiency
- Solar digital thermometer in refrigerated section
- Fully adjustable shelving allows for maximum merchandising flexibility (refrigerated section)
- Price tag molding on refrigerated shelf facings
- Conforms to UL 471, NSF 7 and CAN/CSA 22.2

Self-contained options:

- Copeland condensing unit
- Slide out bottom mounted refrigeration for serviceability
- Dixell case controller features automatic defrost
- Electric condensation evaporation
- Removable vented panel for easy access to clean the condenser coil

Remote options:

- Sporlan externally equalized TXV per refrigerant type
- Optional installation of customer-specified third-party probes
- Optional glycol refrigeration
- Optional refrigeration shutoff valves
- Optional bottom-mounted electric condensate evaporator

Other options available:

- Durable powder coated interior finish
- Available private label branding with applied vinyl graphics
- Ultra efficient LED lights

Contact your Amtekco sales representative: 1-800-336-4677

amtekco

A Wasserstrom Company

Manufacturers of Quality Products for the Food Marketing Industry

Equipment That Means Business