

Work Top Refrigerators

Top:

Constructed of heavy-gauge 300 series stainless steel #3 finish, designed for maximum rigidity and for many years of service.

Refrigeration:

Wasserstrom exclusive "slim line" unit cooler design is recessed inside the rear refrigerator wall to offer maximum unobstructed storage and facilitate cleaning. The evaporator shroud is constructed of stainless steel for dent and corrosion resistance. The evaporator coil is provided with a thermal expansion valve for quick recovery and the coil is double coated with a special epoxy coating for protection against corrosion caused by food acids and cleaning chemicals. The condensing unit is positioned for easy serviceability and it is provided with an energy-saving hot gas condensate evaporator that saves on electricity. The entire cabinet is foamed-in-place with high-density polyurethane insulation up to 3" thick for maximum energy efficiency.

Exterior:

Heavy-gauge stainless steel fronts, tops and sides. The rear, bottom and compressor housing are constructed of heavy-gauge galvanized steel.

Doors:

Fronts and liners are constructed of heavy-gauge stainless steel and foamed-in-place with high-density polyurethane insulation and welded corners. Doors are provided with magnetic gaskets for positive seals and they are fitted with heavy-duty die cast hinges to withstand abuse.

Tailored to Your Needs:

Just one of the benefits of our complete in-house design, fabricating and manufacturing capabilities, is the fact that any of our Refrigerated Prep Tables can be tailored to fit your exact functional needs and interior décor preferences. Just let us know what you want, and our professional design staff will make it a reality.

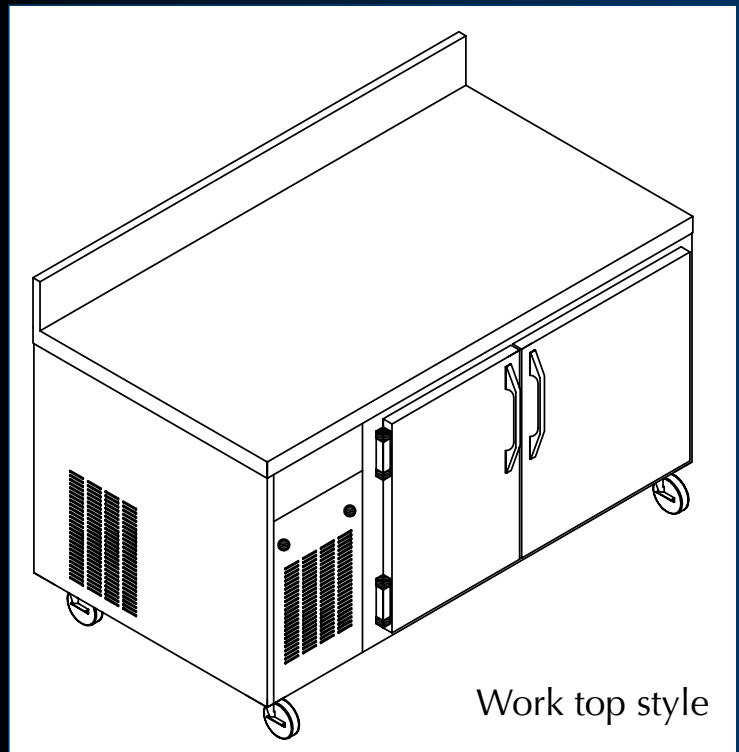

Work top style

Standard Features:

- Hot gas condensate evaporator uses no electricity
- Heavy-duty casters
- Electronic temperature controller for maximum accuracy with LED display
- Coated evaporator coil for protection against corrosion
- Heavy-duty refrigeration system with expansion valve environmentally friendly HFC-404A
- 8-foot long electrical cord included

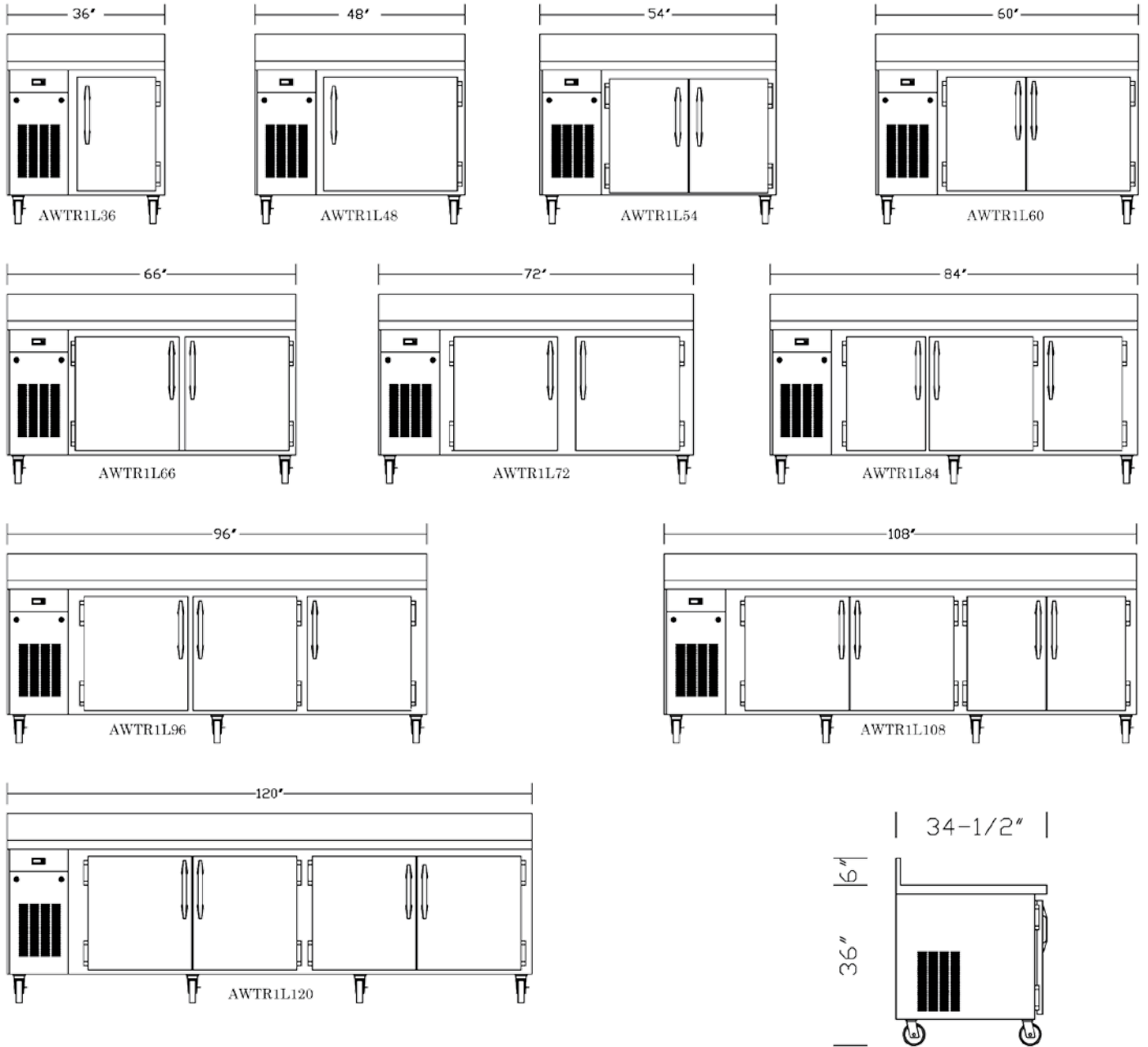

STANDARD PROFILE

DRAWING #	LENGTH	DEPTH	HEIGHT	NUMBER OF DOORS	COMPRESSOR	AMPS	VOLTAGE	SHIP WEIGHT
AWTR1L36	36"	34-1/2"	36"	1	1/2	5.24	115/60/1	375
AWTR1L48	48"	34-1/2"	36"	1	1/2	5.24	115/60/1	443
AWTR1L54	54"	34-1/2"	36"	2	1/2	5.57	115/60/1	479
AWTR1L60	60"	34-1/2"	36"	2	1/2	5.57	115/60/1	513
AWTR1L66	66"	34-1/2"	36"	2	1/2	5.9	115/60/1	546
AWTR1L72	72"	34-1/2"	36"	2	1/4	8.27	115/60/1	606
AWTR1L84	84"	34-1/2"	36"	3	1/4	8.27	115/60/1	676
AWTR1L96	96"	34-1/2"	36"	3	1/2	8.99	115/60/1	744
AWTR1L108	108"	34-1/2"	36"	4	1/2	8.99	115/60/1	814
AWTR1L120	120"	34-1/2"	36"	4	1/2	9.32	115/60/1	887