

SECTION A-A
SCALE 0.500

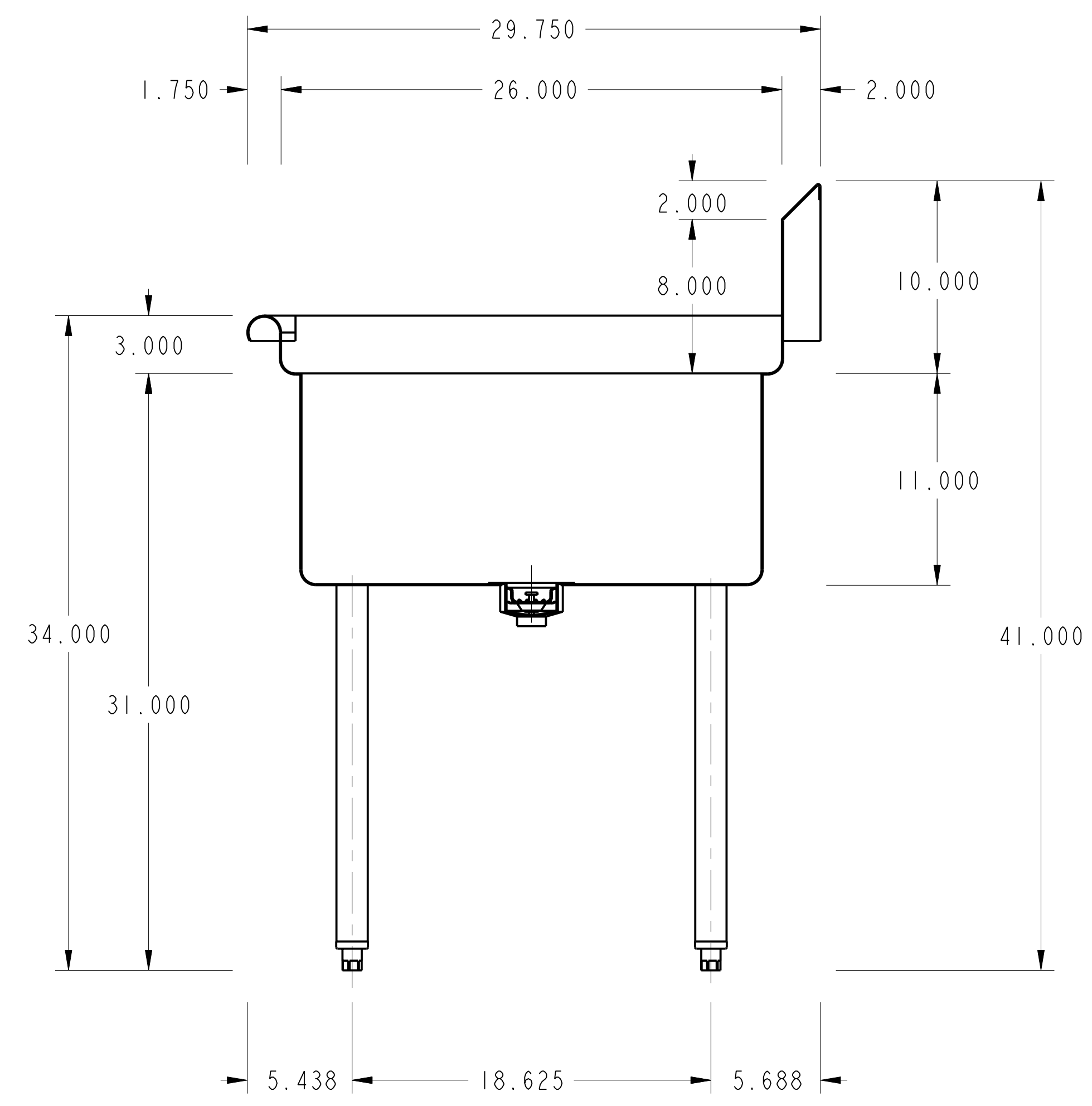
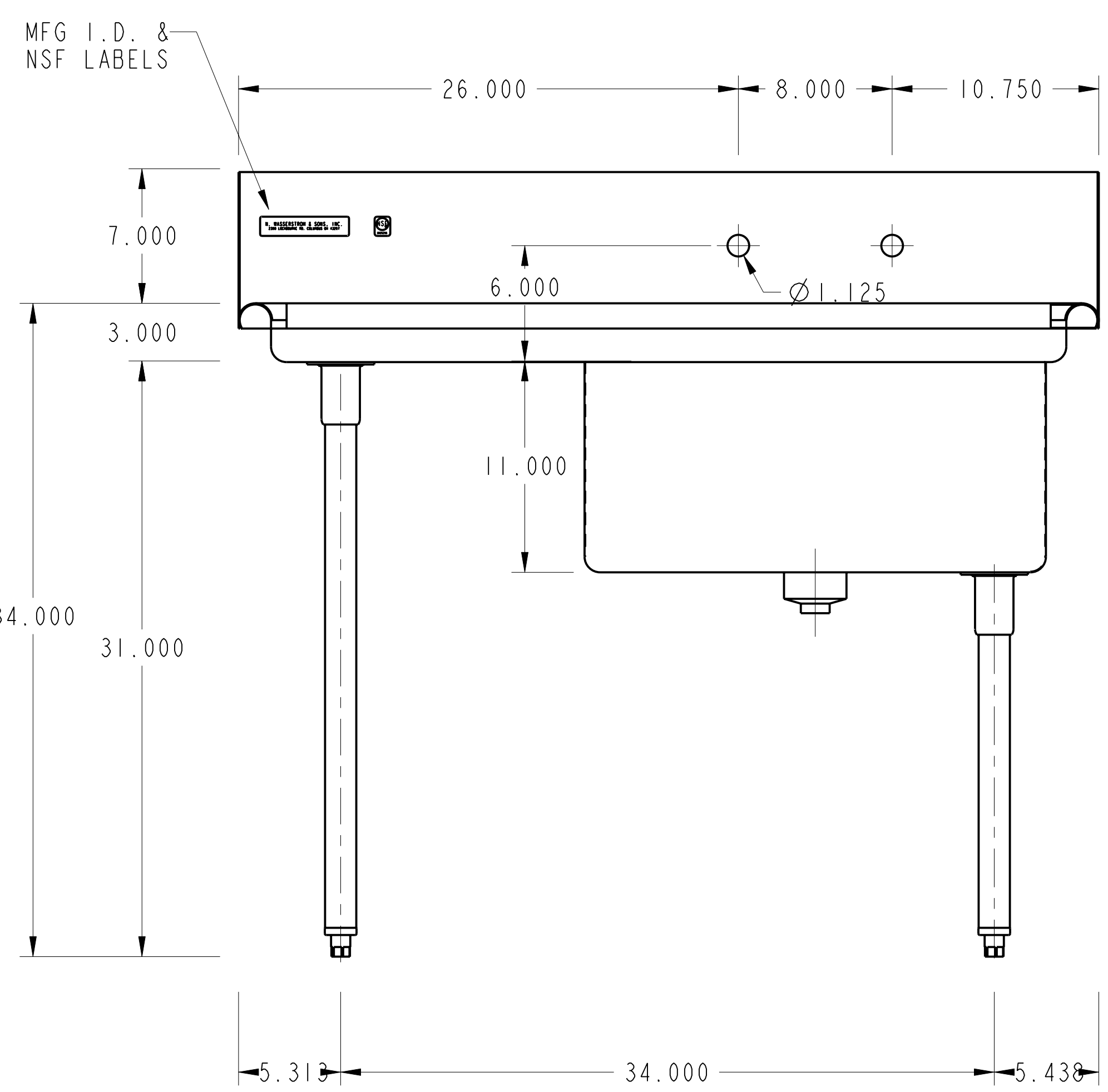

SECTION A-A

PURCHASED ITEMS

KEY	DESCRIPTION	QTY.	U/M	INV. CODE	VENDOR NAME	PART/MODEL NUMBER	PART TYPE
1	DUO BASKET DRAIN, E38-1010	1	EA	BI	COMPONENT	E38-1010	ASSEMBLY
2	LEG GUSSET	4	EA	BI	COMPONENT	A18-0406	PART
3	S/S ADJUSTABLE BULLET FOOT	4	EA	BI	COMPONENT	A10-0851	PART

- TOP: 16 GA. STN/STL ALL WELDED CONSTRUCTION w/ INTEGRAL 10" BACK & RIGHT SIDE SPLASH. ALL HORIZONTAL AND VERTICAL CORNERS TO BE COVERED TO A 3/4" RADIUS. SINKS TO BE WELDED INTEGRAL AS SHOWN. CREASE DRAINBOARD.
- SINKS: 16 GA. S/S ALL WELDED CONSTRUCTION. ALL INTERIOR CORNERS TO BE COVERED TO A 3/4" RAD. WITH SPHERICAL INTERSECTIONS. BOTTOM TO BE CREASE TO OPENING FOR LEVER ACTION WASTE AS SHOWN.
- LEGS: 1 5/8" O.D. 16 GA. STN/STL TUBING HELD IN STN/STL LEG HOLDERS WHICH ARE STUD BOLTED TO UNDER SIDE OF SINK BOWLS.
- FEET: STN/STL ADJUSTABLE BULLET TYPE.
- NOTES: ALL STN/STL TO BE TYPE 304.
ALL STN/STL TO BE POLISHED TO A NO. 5 FINISH.
ALL UNEXPOSED WELDS TO BE COVERED w/ ALUMINUM PAINT.
ALL METAL EDGES AND CORNERS TO BE FILED SMOOTH.

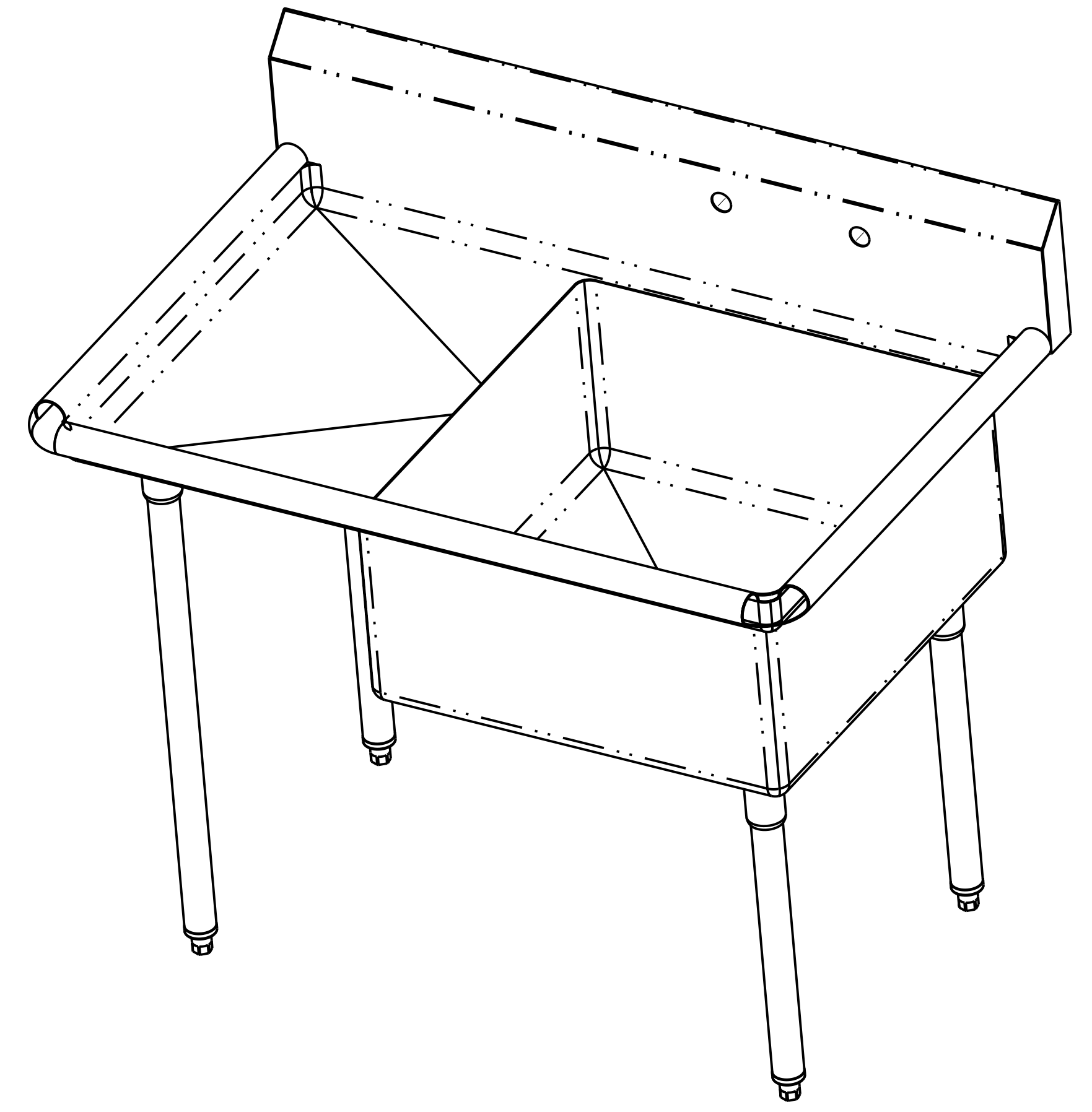

NO.	DATE	REVISIONS	BY
ASSEM		C-1-2424-18L	



THIS DRAWING IS THE PROPERTY OF AMTEKCO INDUSTRIES, INC. AND IS TO REMAIN IN THE POSSESSION OF OUR REPRESENTATIVE UNLESS PERMISSION IS GIVEN BY AMTEKCO INDUSTRIES, INC. AND MUST BE RETURNED WHEN REQUESTED.