

PURCHASED ITEMS

KEY	DESCRIPTION	QTY.	U/M	INV. CODE	VENDOR NAME	PART/MODEL NUMBER	PART TYPE
1	DUO BASKET DRAIN, E38-1010	1	EA	BI	COMPONENT	E38-1010	ASSEMBLY
2	LEG GUSSET	4	EA	BI	COMPONENT	A18-0406	PART
3	S/S ADJUSTABLE BULLET FOOT	4	EA	BI	COMPONENT	A10-0851	PART

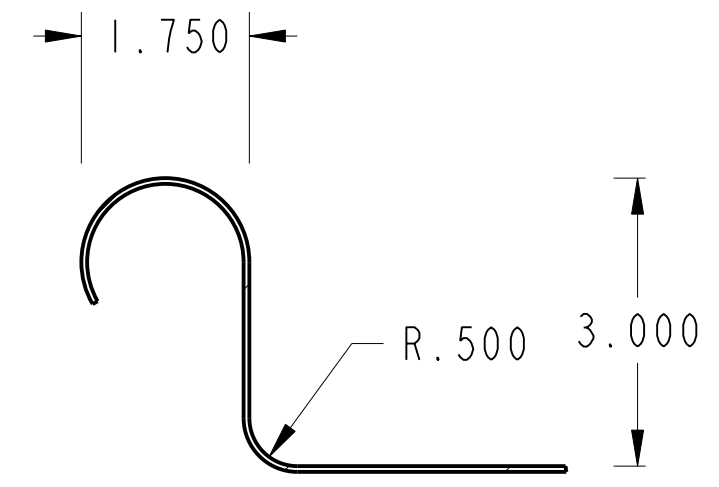
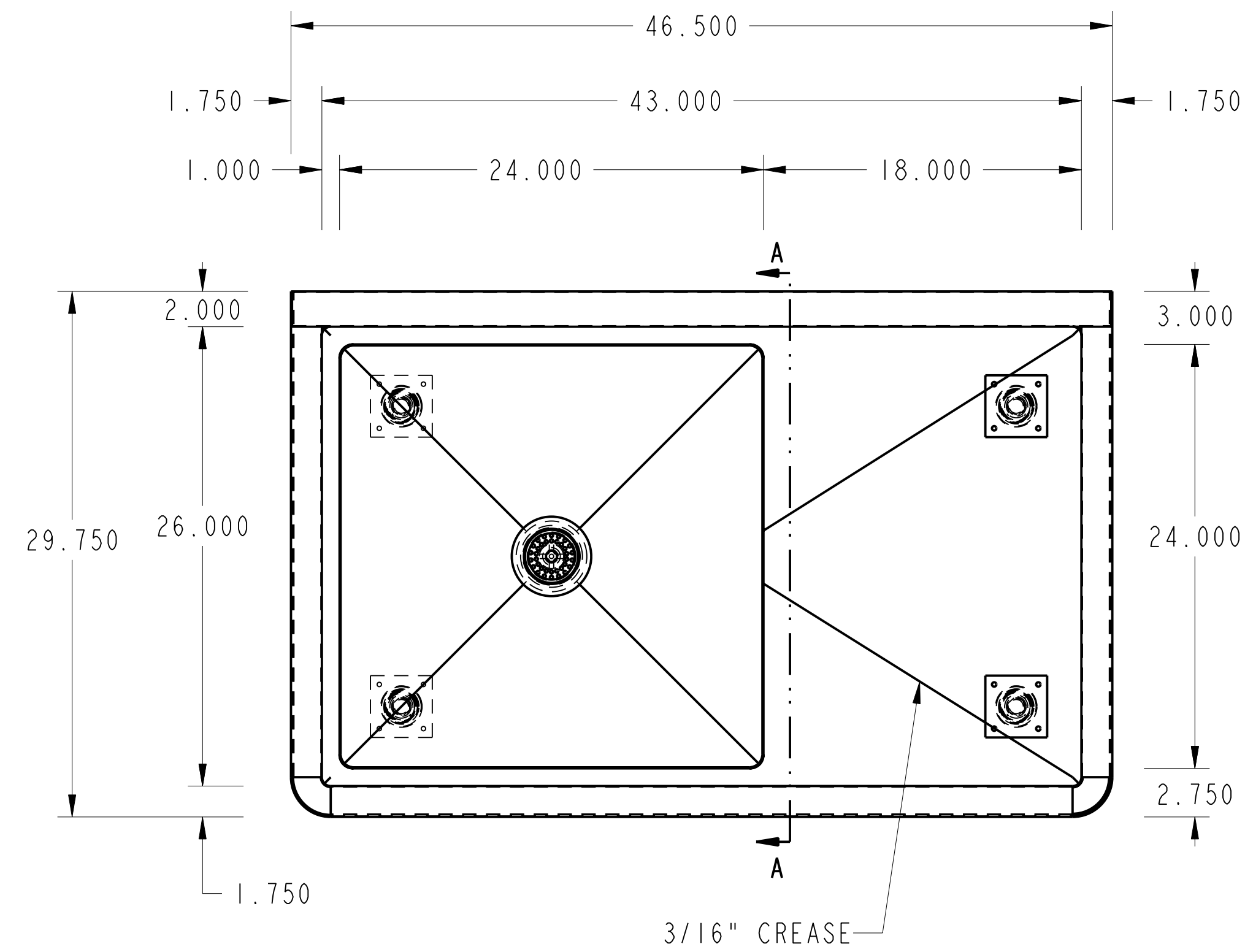

SECTION A-A
SCALE 0.500

ITEM# 1 COMP SINK (1) REQ'D.

TOP: 16 GA. STN/STL ALL WELDED CONSTRUCTION w/ INTEGRAL 10" BACK SPLASH. CORNERS TO BE COVED TO A 1/2" RADIUS. SINKS TO BE WELDED INTEGRAL AS SHOWN.

SINKS: 16 GA. STN/STL ALL WELDED CONSTRUCTION. ALL INTERIOR CORNERS TO BE COVED TO A 3/4" RADIUS WITH SPHERICAL INTERSECTIONS. BOTTOM TO BE CREASE TO OPENING FOR DRAIN WASTE AS SHOWN.

LEGS: 1 5/8" O.D. 16 GA. STN/STL TUBING HELD IN STN/STL LEG HOLDERS WHICH ARE STUD BOLTED TO UNDER SIDE OF SINK BOWLS.

FEET: STN/STL ADJUSTABLE BULLET TYPE.

NOTES: ALL STN/STL TO BE TYPE 300 SERIES.
ALL STN/STL TO BE POLISHED TO A NO. 5 FINISH.
ALL UNEXPOSED WELDS TO BE COVERED w/ ALUMINUM PAINT.
ALL METAL EDGES AND CORNERS TO BE FILED SMOOTH.

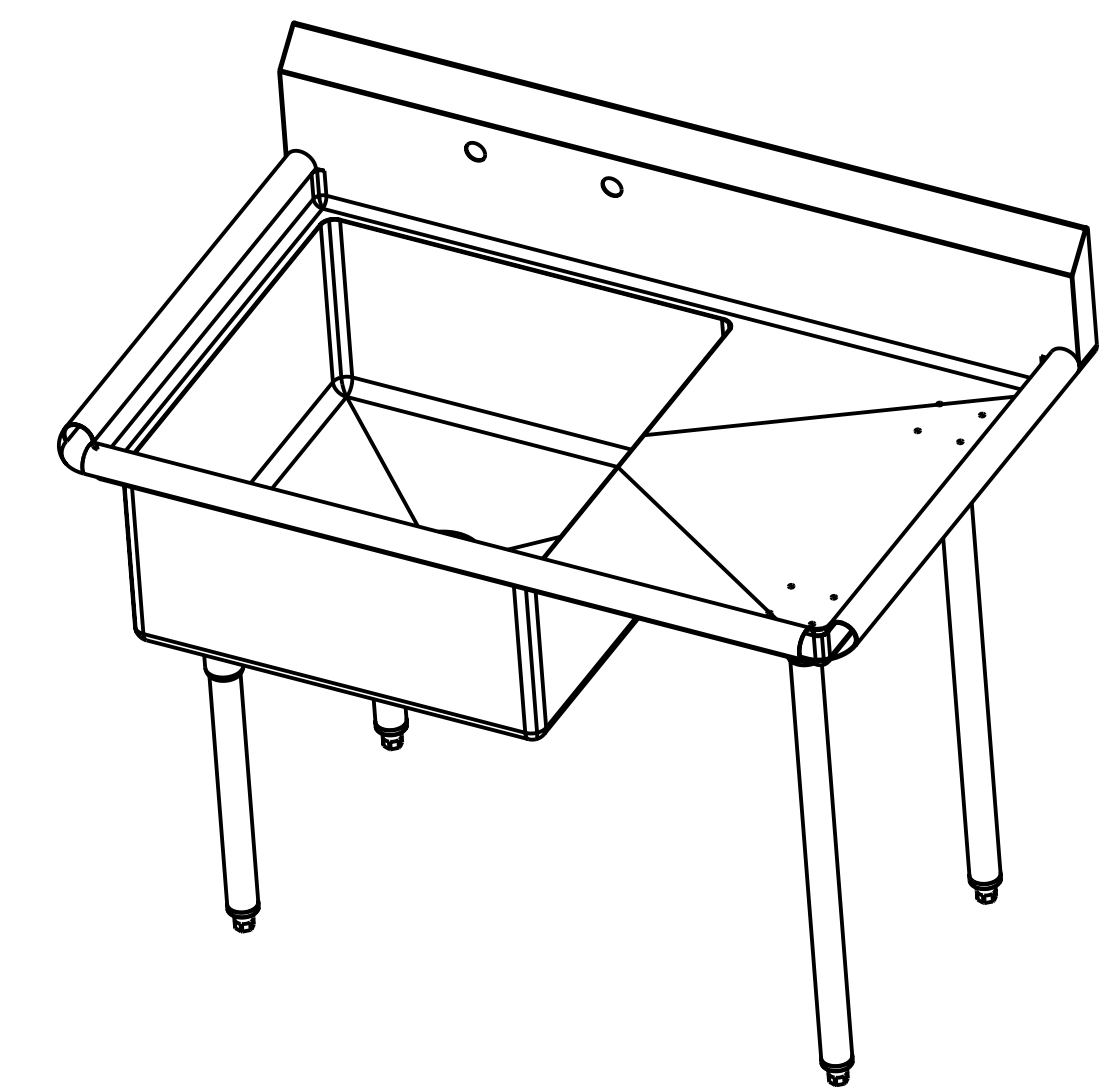

SCALE 0.100

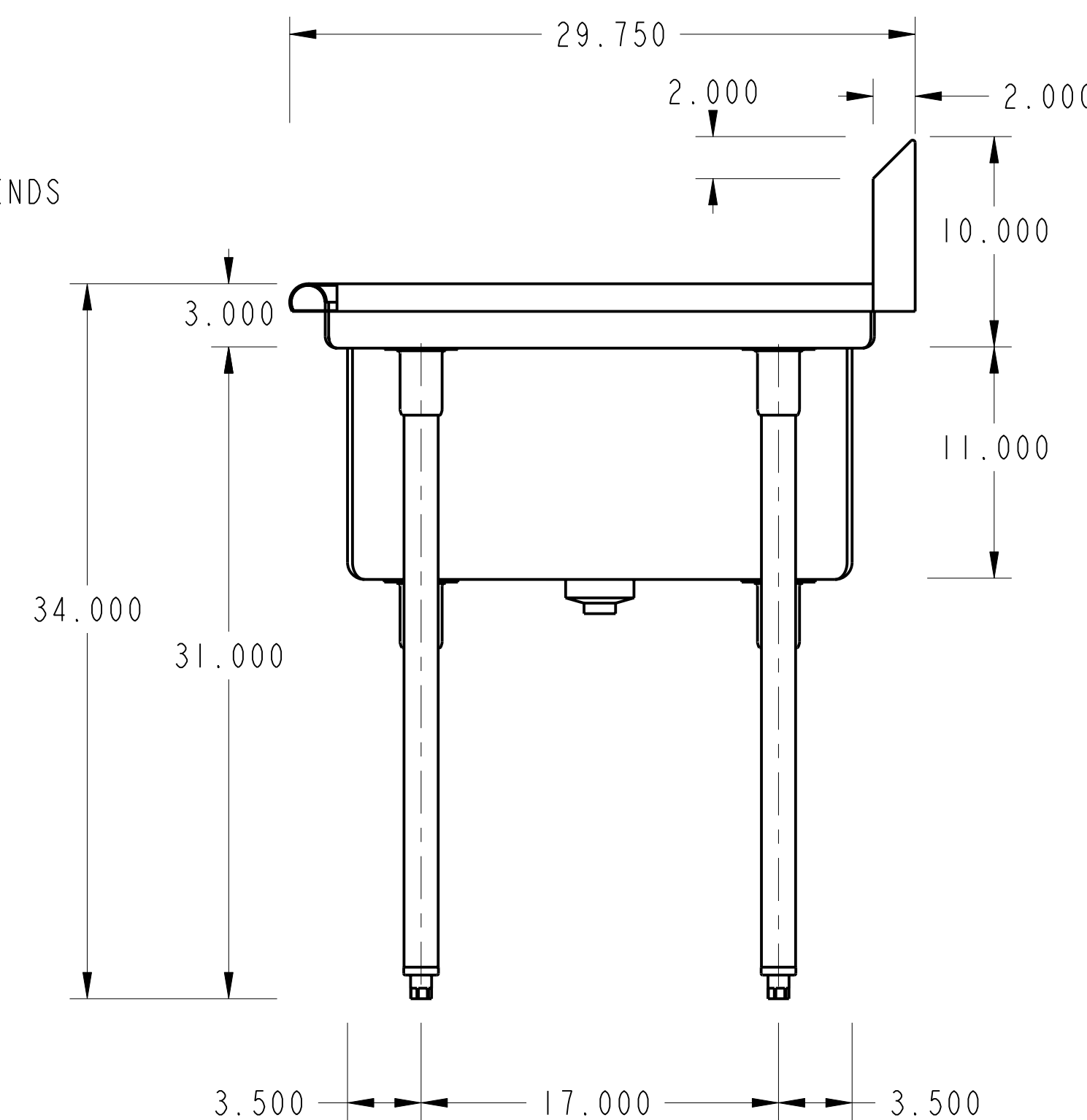
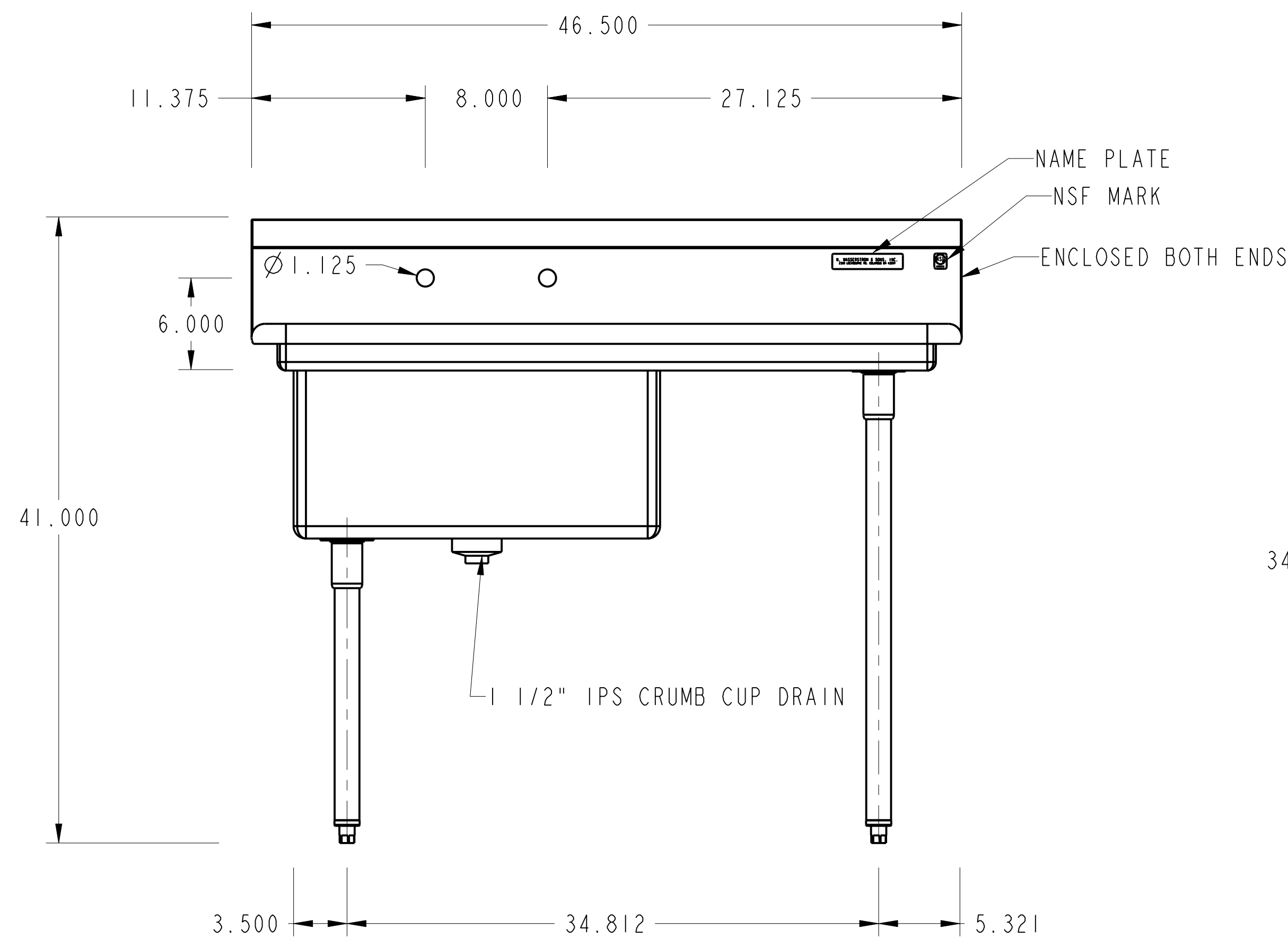

#225563 (1) EACH LABEL IS TO BE PLACED ON BACKSPLASH OR NOSING

NO.	DATE	REVISIONS	BY
ASSEM		C-1-2424-18R	



PRO

AMTEKCO INDUSTRIES, INC.

MANUFACTURERS OF QUALITY PRODUCTS FOR THE FOOD MARKETING INDUSTRY
1205 REFUGEE ROAD COLUMBUS, OHIO 43207
(614)228-6590 Fax (614)737-8016

AMTEKCO

44 3/4" X 29 3/4" 1-COMP SINK

THIS DRAWING IS THE PROPERTY OF AMTEKCO INDUSTRIES, INC. AND IS TO REMAIN IN THE POSSESSION OF OUR REPRESENTATIVE UNLESS PERMISSION IS GIVEN BY AMTEKCO INDUSTRIES, INC. AND MUST BE RETURNED WHEN REQUESTED.

APPROVED BY	CKD BY	DATE	SCALE	
		07-Sep-06	0.150	
DATE	CODE	DRAWING No.	REV.	PART/SHEET
				C-1-2424-18R