

SECTION A-A  
SCALE 0.500

PURCHASED ITEMS							
KEY	DESCRIPTION	QTY.	U/M	INV. CODE	VENDOR NAME	PART/MODEL NUMBER	PART TYPE
1	DUO BASKET DRAIN, E38-1010	2	EA	BI	COMPONENT	E38-1010	ASSEMBLY
2	LEG GUSSET	4	EA	BI	COMPONENT	A18-0406	PART
3	S/S ADJUSTABLE BULLET FOOT	4	EA	BI	COMPONENT	A10-0851	PART

- TOP: 16 GA. STN/STL ALL WELDED CONSTRUCTION w/ INTEGRAL 10" BACK. ALL HORIZONTAL AND VERTICAL CORNERS TO BE COVED TO A 1/2" RADIUS. SINKS TO BE WELDED INTEGRAL AS SHOWN.
- SINKS: 16 GA. STN/STL ALL WELDED CONSTRUCTION. ALL INTERIOR CORNERS TO BE COVED TO A 3/4" RAD. WITH SPHERICAL INTERSECTIONS.
- LEGS: 1 5/8" O.D. 16 GA. STN/STL TUBING HELD IN STN/STL LEG HOLDERS WHICH ARE FULLY WELDED TO REINFORCING PLATE ON UNDER SIDE OF SINK BOWLS.
- FEET: STN/STL ADJUSTABLE BULLET TYPE.
- NOTES: ALL STN/STL TO BE TYPE 300 SERIES.  
ALL STN/STL TO BE POLISHED TO A NO. 5 FINISH.  
ALL UNEXPOSED WELDS TO BE COVERED w/ ALUMINUM PAINT.  
ALL METAL EDGES AND CORNERS TO BE FILED SMOOTH.

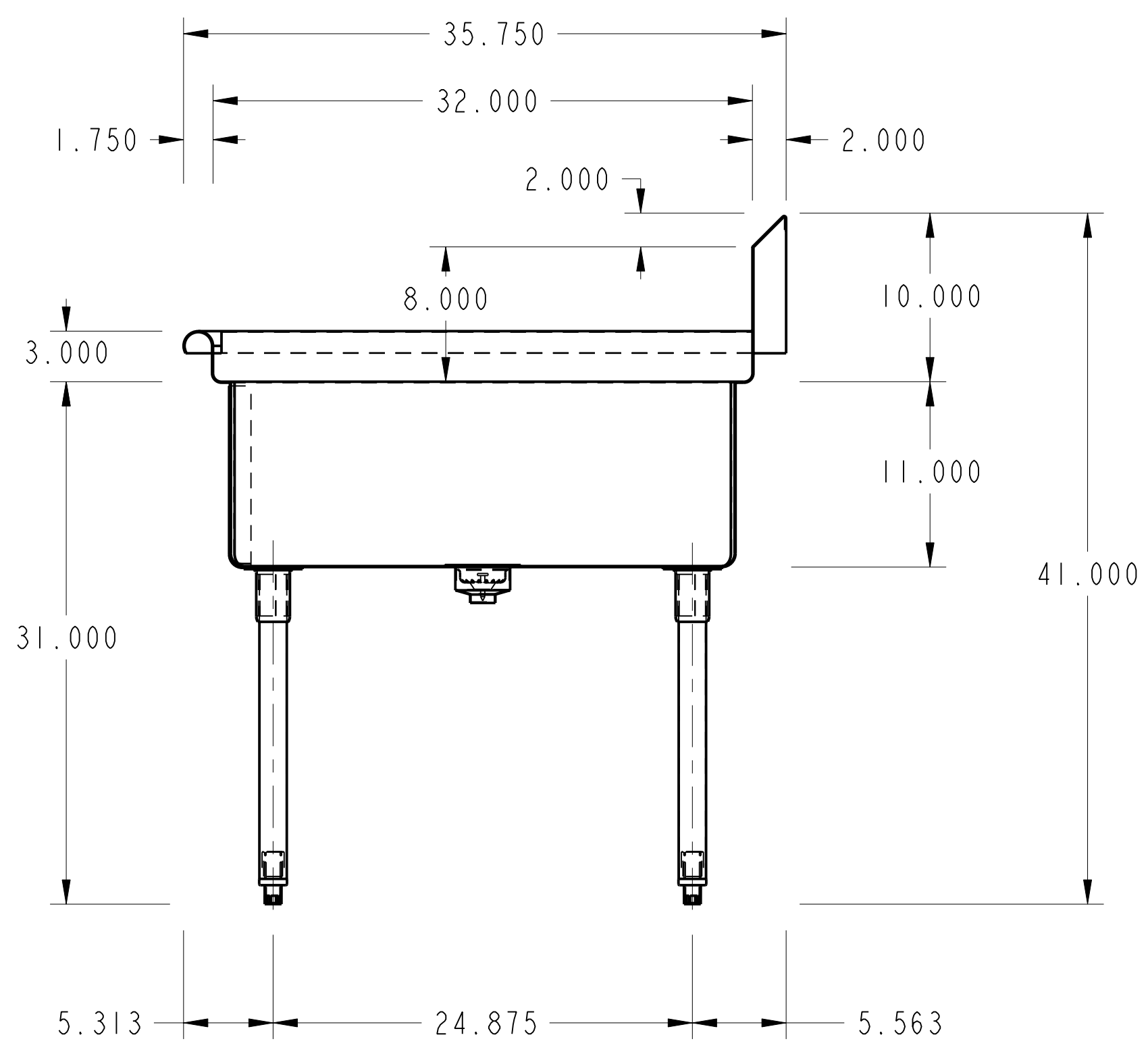
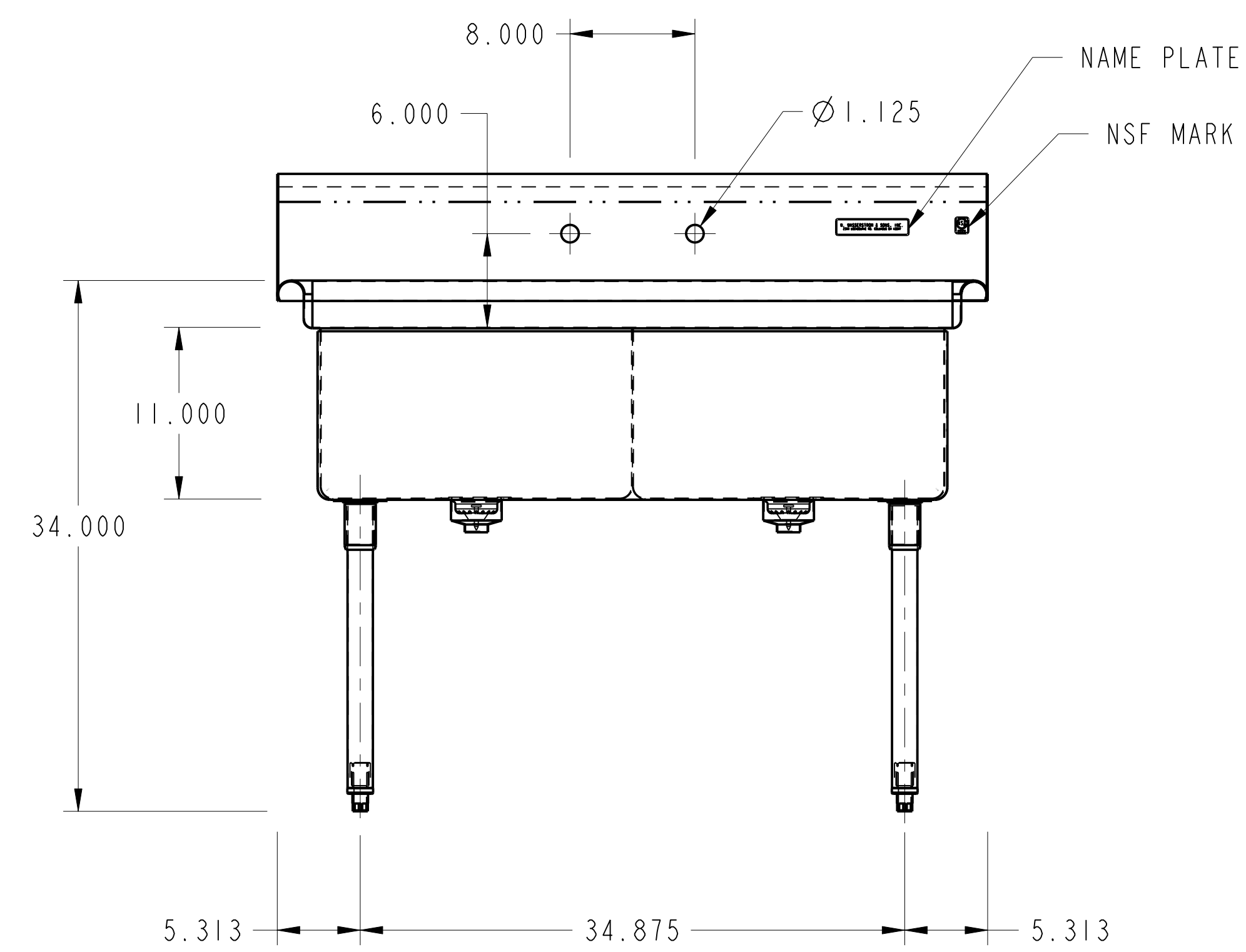

SECTION A-A

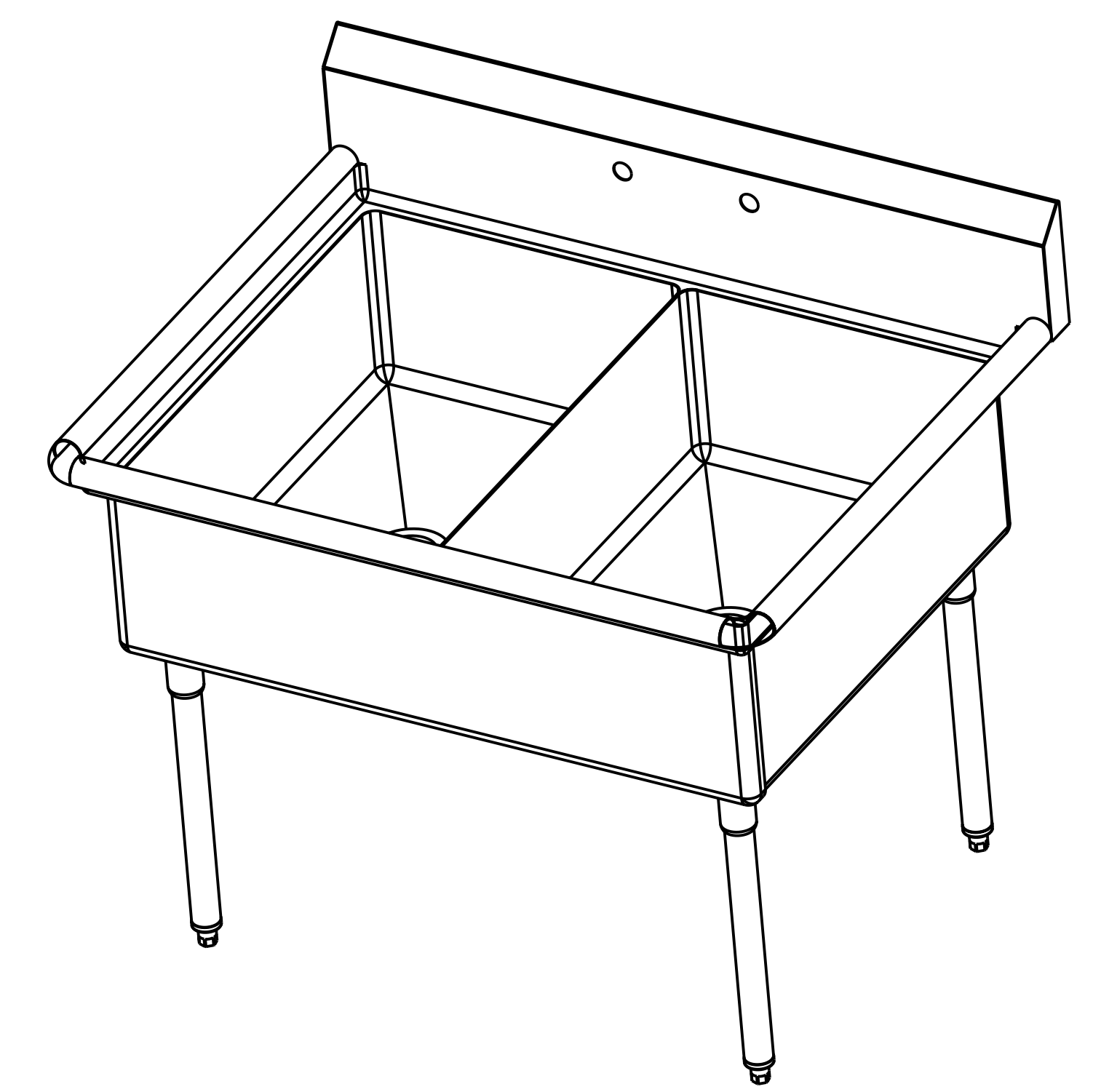

NO.	DATE	REVISIONS	BY
ASSEM		C-2-2030	

