

PURCHASED ITEMS

KEY	DESCRIPTION	QTY.	U/M	INV. CODE	VENDOR NAME	PART/MODEL NUMBER	PART TYPE
1	DUO BASKET DRAIN, E38-1010	3	EA	BI	COMPONENT	E38-1010	ASSEMBLY
2	LEG GUSSET	4	EA	BI	COMPONENT	A18-0406	PART
3	S/S ADJUSTABLE BULLET FOOT	4	EA	BI	COMPONENT	A10-0851	PART
4	ADD ON FAUCET FOR PRE-RINSE UNIT	1	EA	BI	T & S	B-0156	PART
5	PRE-RINSE (WALL MOUNTED)	1	EA	BI	T & S	B-0133	PART
6	SOLID CORE POLYTOP (CUT AT 18" X 27")	1	EA	BI	TBD	AMT9159P001	PART

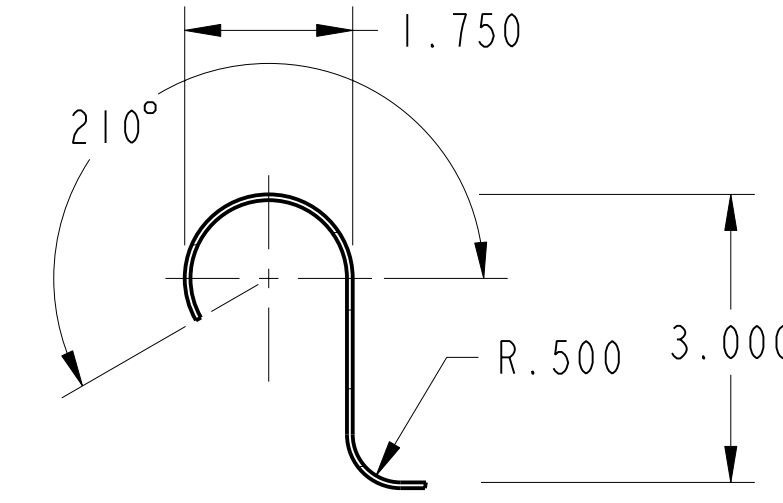
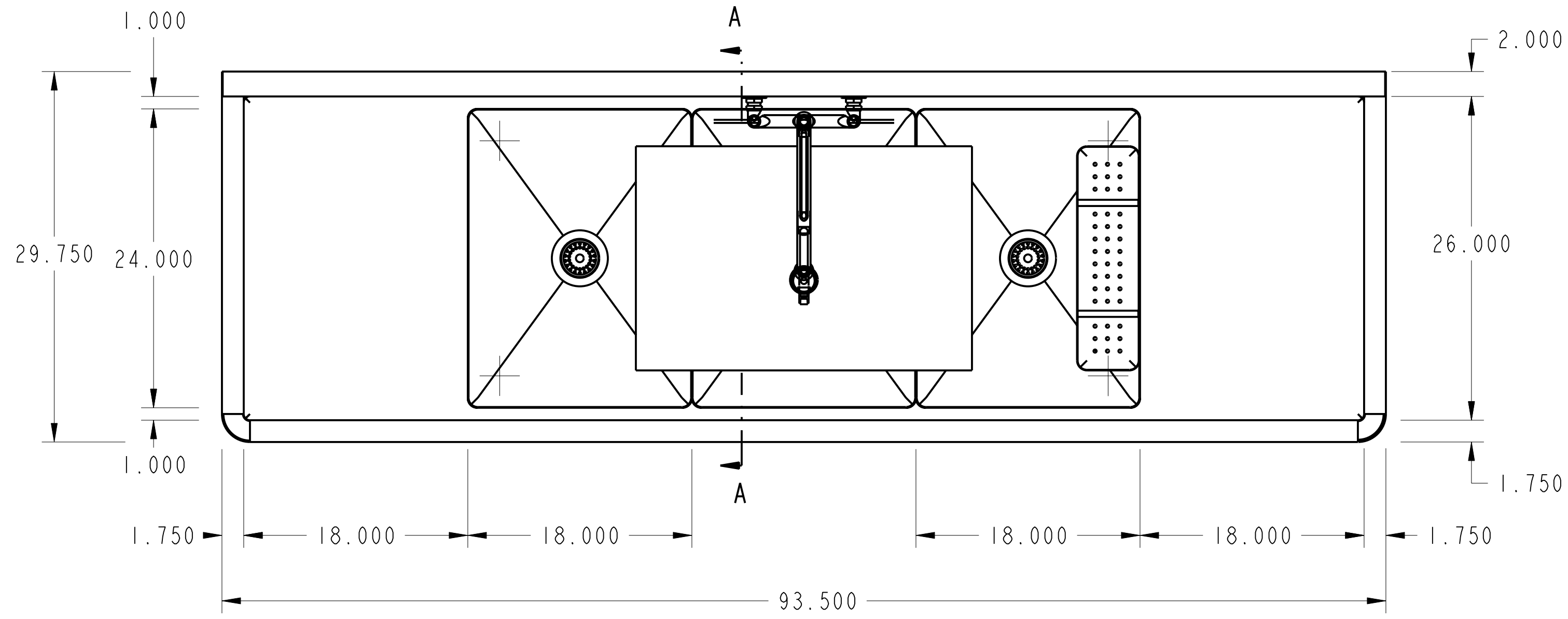

TOP: 16 GA. STN/STL ALL WELDED CONSTRUCTION w/ INTEGRAL 10" BACK & RIGHT SIDE SPLASH. ALL HORIZONTAL AND VERTICAL CORNERS TO BE COVERED TO A 1/2" RADIUS. SINKS TO BE WELDED INTEGRAL AS SHOWN.

SINKS: 16 GA. STN/STL ALL WELDED CONSTRUCTION. ALL INTERIOR CORNERS TO BE COVERED TO A 3/4" RAD. WITH SPHERICAL INTERSECTIONS. BOTTOM TO BE CREASE TO OPENING FOR CRUMB CUP WASTE AS SHOWN.

LEGS: 1 5/8" O.D. 16 GA. STN/STL TUBING HELD IN STN/STL LEG HOLDERS WHICH ARE FULLY WELDED TO REINFORCING PLATE ON UNDER SIDE OF SINK BOWLS.

FEET: STN/STL ADJUSTABLE BULLET TYPE.

NOTES: ALL STN/STL TO BE TYPE 300 SERIES. ALL STN/STL TO BE POLISHED TO A NO. 5 FINISH. ALL UNEXPOSED WELDS TO BE COVERED w/ ALUMINUM PAINT. ALL METAL EDGES AND CORNERS TO BE FILED SMOOTH.

SECTION A-A
SCALE 0.500

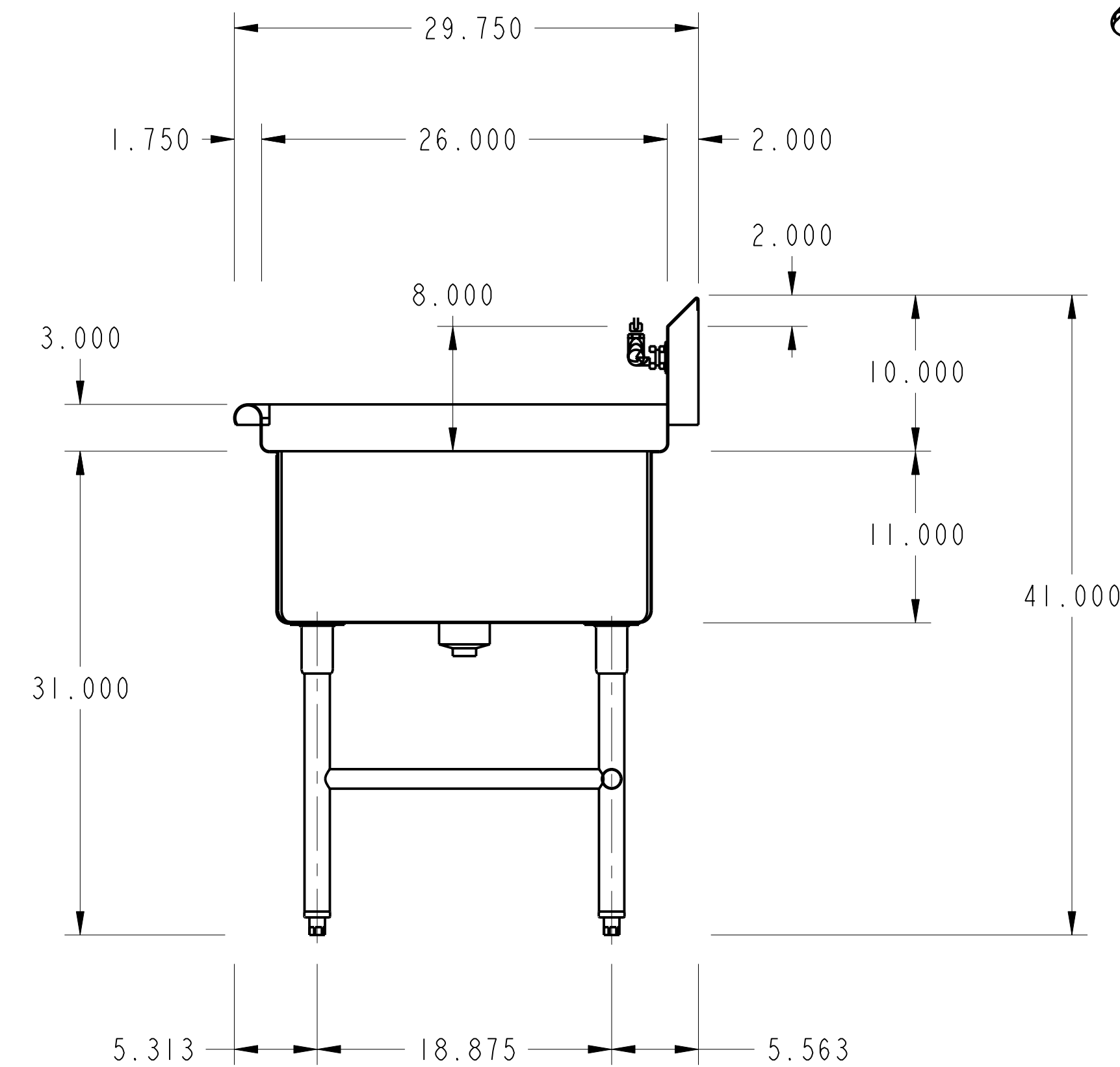
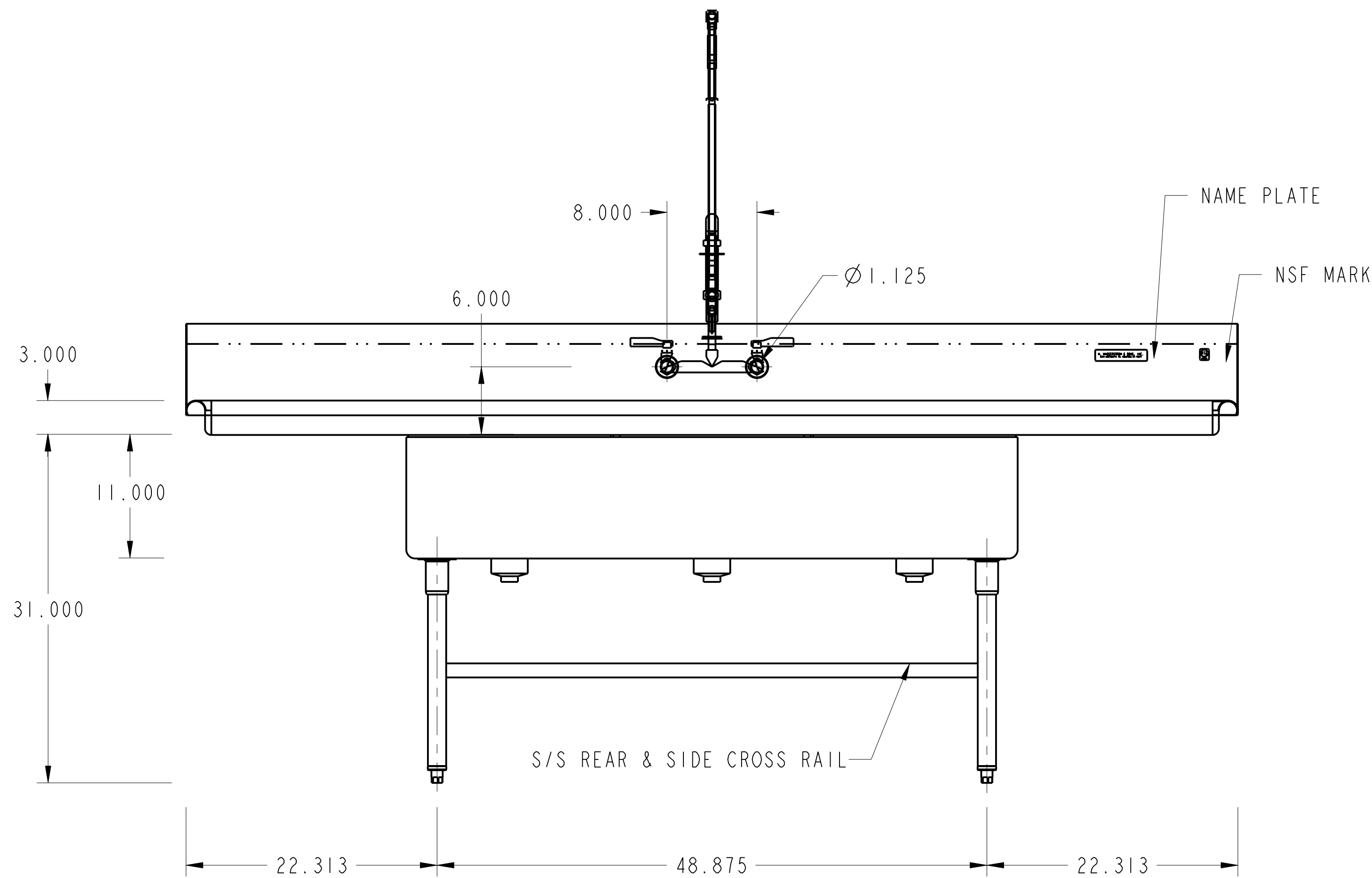
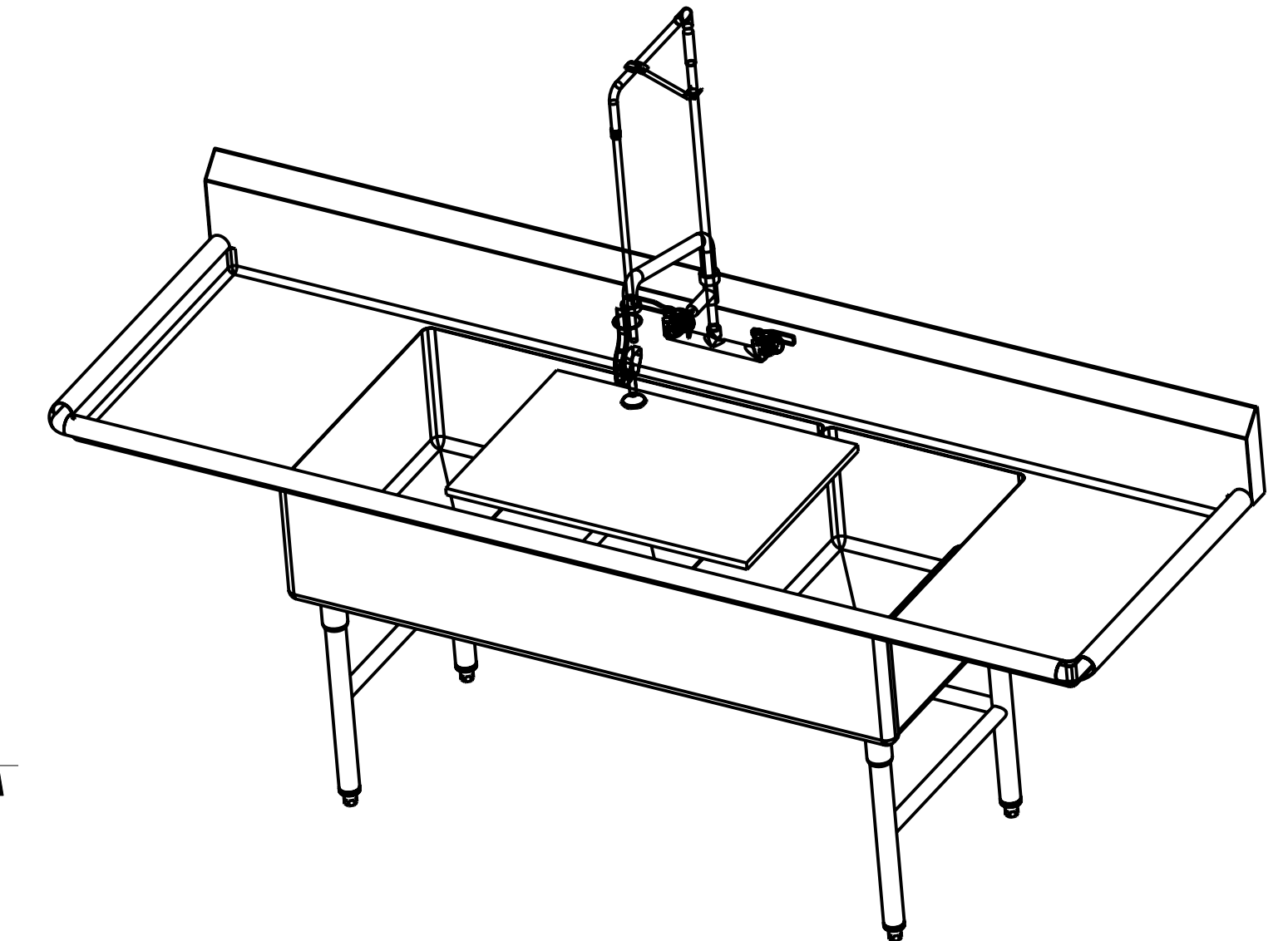

SECTION A-A

NO.	DATE	REVISIONS	BY
ASSEM		CRFFPS-1824-DN	

