

PURCHASED ITEMS

KEY	DESCRIPTION	QTY.	U/M	INV. CODE	VENDOR NAME	PART/MODEL NUMBER	PART TYPE
1	1/4"-20 HEX NUT SS W/PLASTIC	19	EA	BI	MISC	250-20_HEXNUT	PART
2	1/4"-20 X 1 1/2" STUD BOLT	19	EA	BI	MISC	1_4-20_STUD	PART

DROP IN TOP : 16 GA. STN/STL ALL WELDED CONSTRUCTION.
 SINK : 16 GA. STN/STL ALL WELDED CONSTRUCTION.
 ALL HORIZONTAL AND VERTICAL CORNERS TO BE A 3/4" RADIUS.

NOTES:
 ALL STN/STL TO BE TYPE 300 SERIES.
 ALL STN/STL TO BE POLISHED TO A NO. 3 FINISH.
 ALL UNEXPOSED WELDS TO BE COVERED W/ ALUMINUM PAINT.
 ALL METAL EDGES AND CORNERS TO BE FILED SMOOTH.

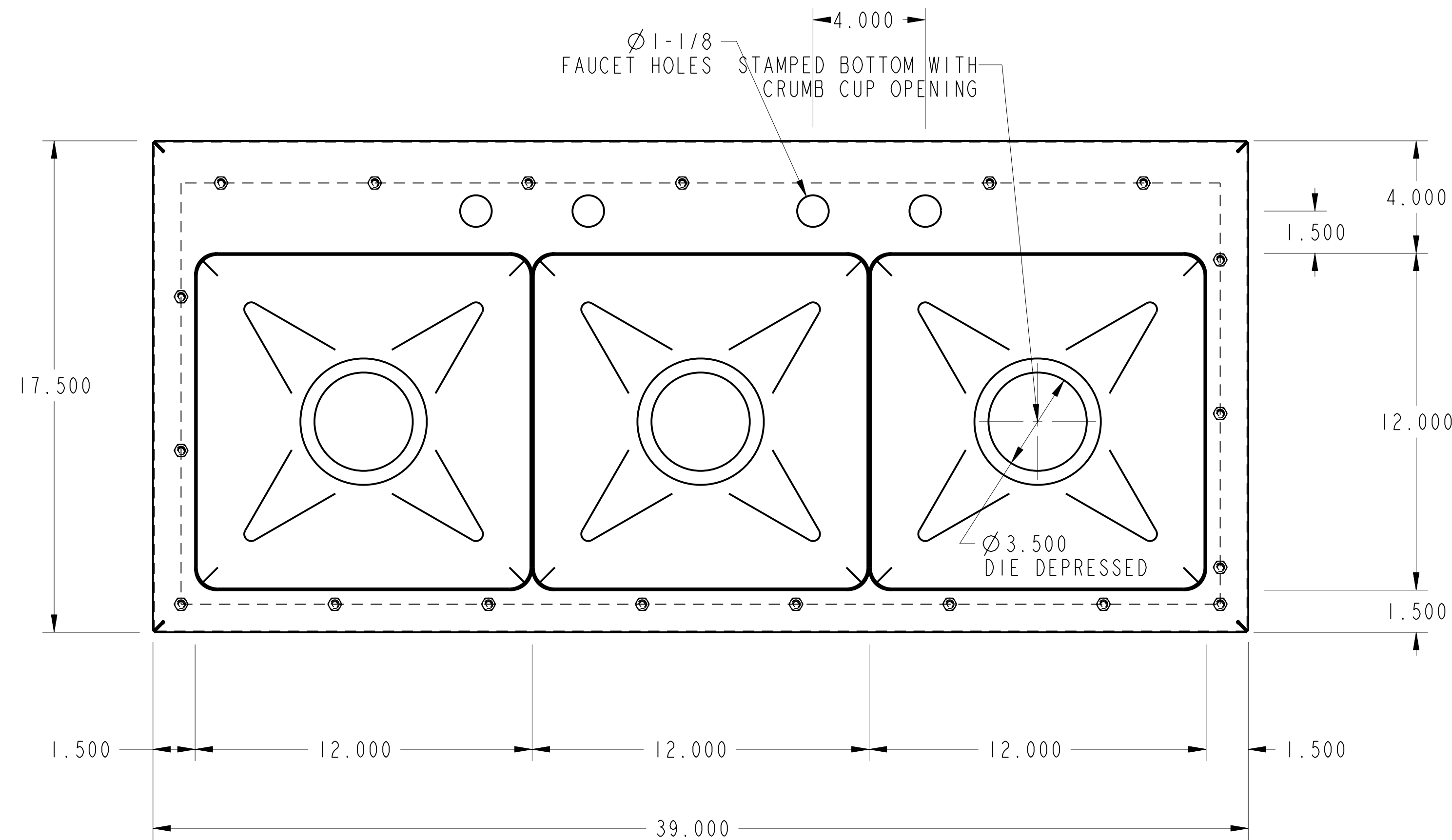

PLAN VIEW

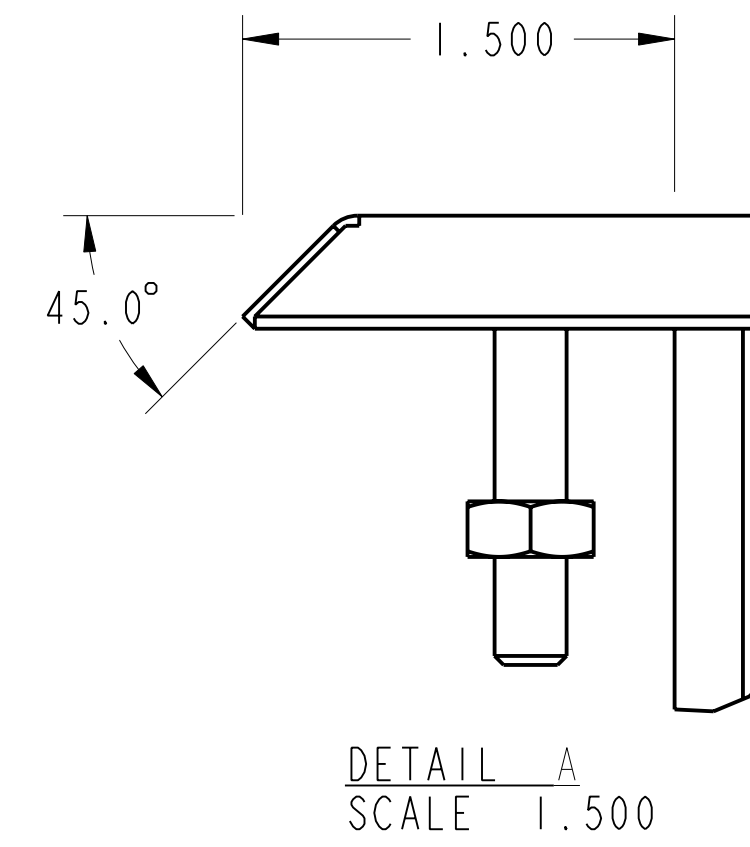

DETAIL A
SCALE 1.500

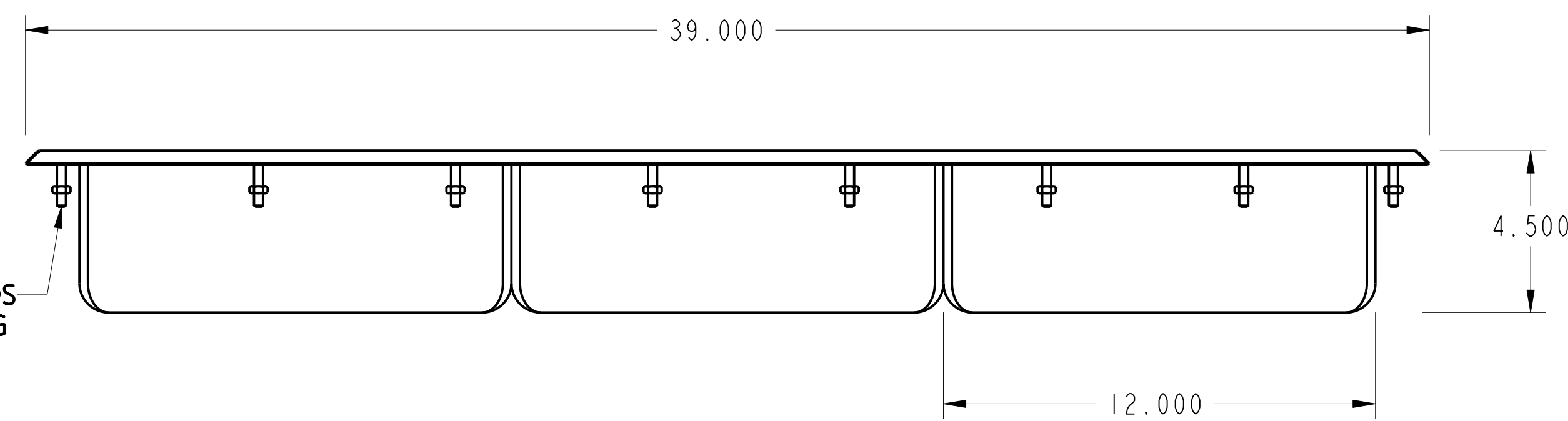
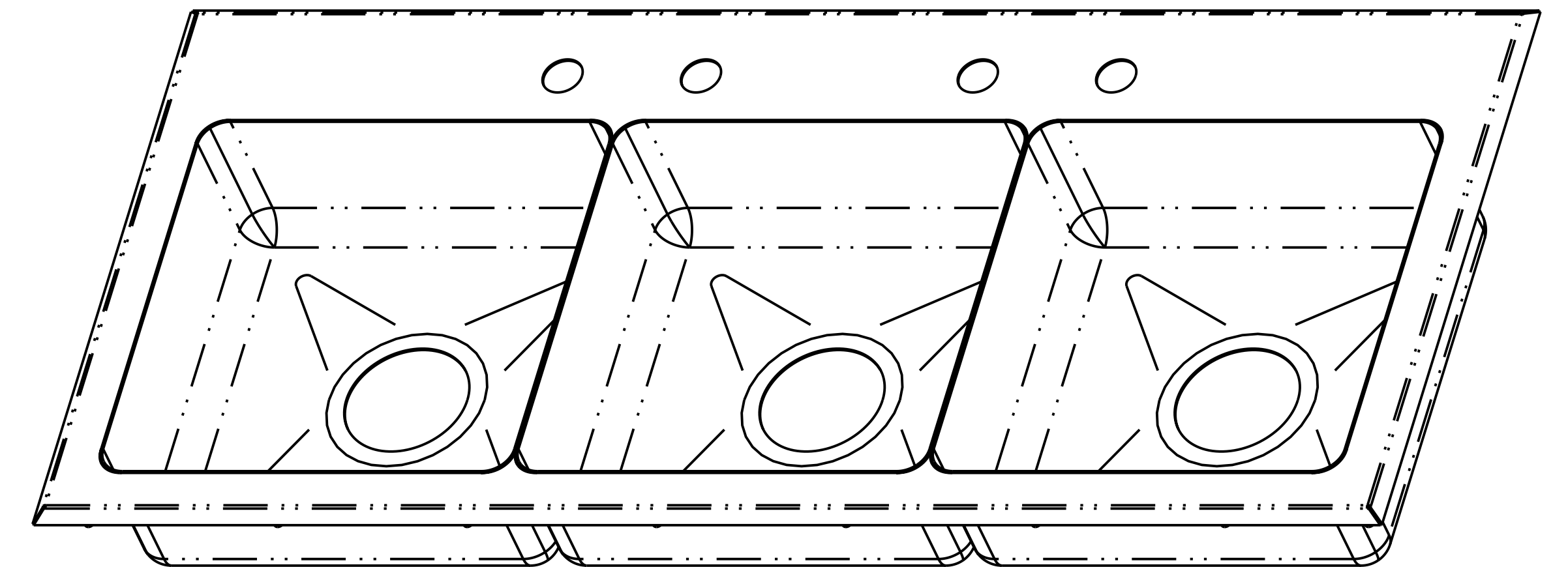

FRONT ELEVATION

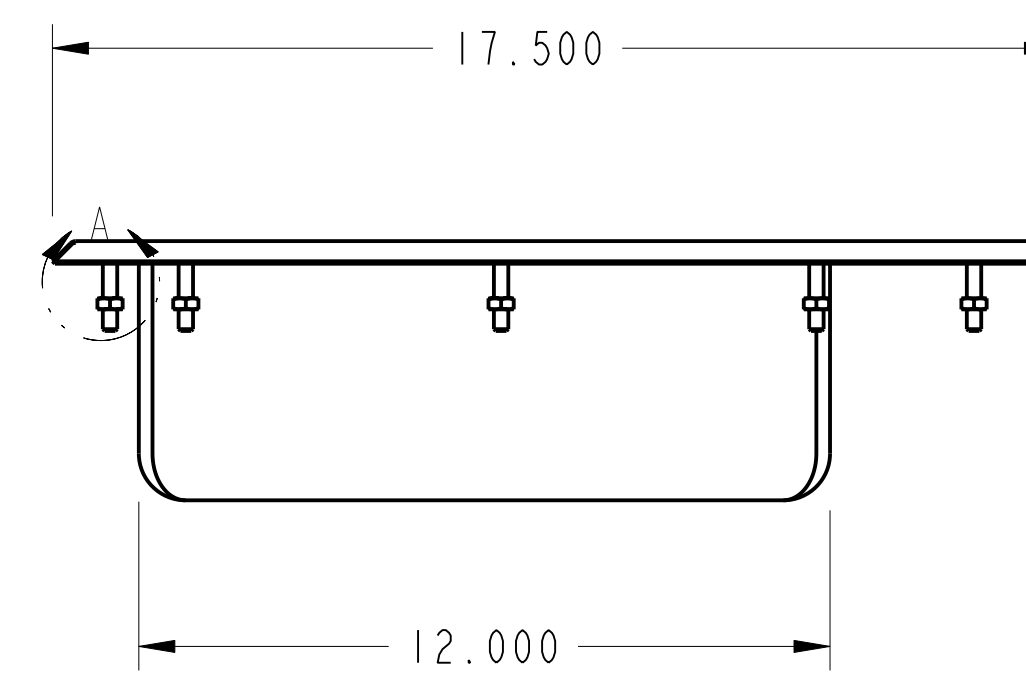

NO.	DATE	REVISIONS	BY
ASSEM		D-3-1212-4_5	



PRO