

PURCHASED ITEMS							
KEY	DESCRIPTION	QTY.	U/M	INV. CODE	VENDOR NAME	PART/MODEL NUMBER	PART TYPE
1	COVERED CORNER INSERT	2	EA	B1	COMPONENT	J70-4691	PART
2	FAUCET	1	EA	B1	COMPONENT	KN55-7012	PART
3	LEG GUSSET	4	EA	B1	COMPONENT	A18-0406	PART
4	S/S ADJUSTABLE BULLET FOOT	4	EA	B1	COMPONENT	A10-0851	PART
5	LA WASTE NO OVERFLOW, FLAT STRAINER	3	EA	B1	COMPONENT	D50-7200_MODIFIED_HANDLE	PART
6	PRE-RINSE UNIT	1	EA	B1	T & S	B-0129	PART

ITEM # 2 COMP SINK

TOP: 14 GA. STN/STL ALL WELDED CONSTRUCTION w/ INTEGRAL BACK SPLASH. ALL HORIZONTAL AND VERTICAL CORNERS TO BE COVERED TO A 3/4" RADIUS. SINKS TO BE WELDED INTEGRAL AS SHOWN.

SINKS: 14 GA. STN/STL ALL WELDED CONSTRUCTION. ALL INTERIOR CORNERS TO BE COVERED TO A 3/4" RAD. WITH SPHERICAL INTERSECTIONS. BOTTOM TO BE CREASE TO OPENING FOR LEVER ACTION WASTE.

LEGS: 1 5/8" O.D. STN/STL TUBING HELD IN STN/STL LEG HOLDERS WHICH ARE FULLY WELDED TO REINFORCING PLATE ON UNDER SIDE OF SINK BOWLS.

CROSS RAILS: 1 1/4" O.D. STN/STL TUBING FULLY WELDED TO LEGS.

FEET: STN/STL ADJUSTABLE BULLET TYPE.

NOTES: ALL STN/STL TO BE TYPE 300 SERIES.
 ALL STN/STL TO BE POLISHED TO A NO. 5 FINISH.
 ALL UNEXPOSED WELDS TO BE COVERED w/ ALUMINUM PAINT.
 ALL METAL EDGES AND CORNERS TO BE FILED SMOOTH.

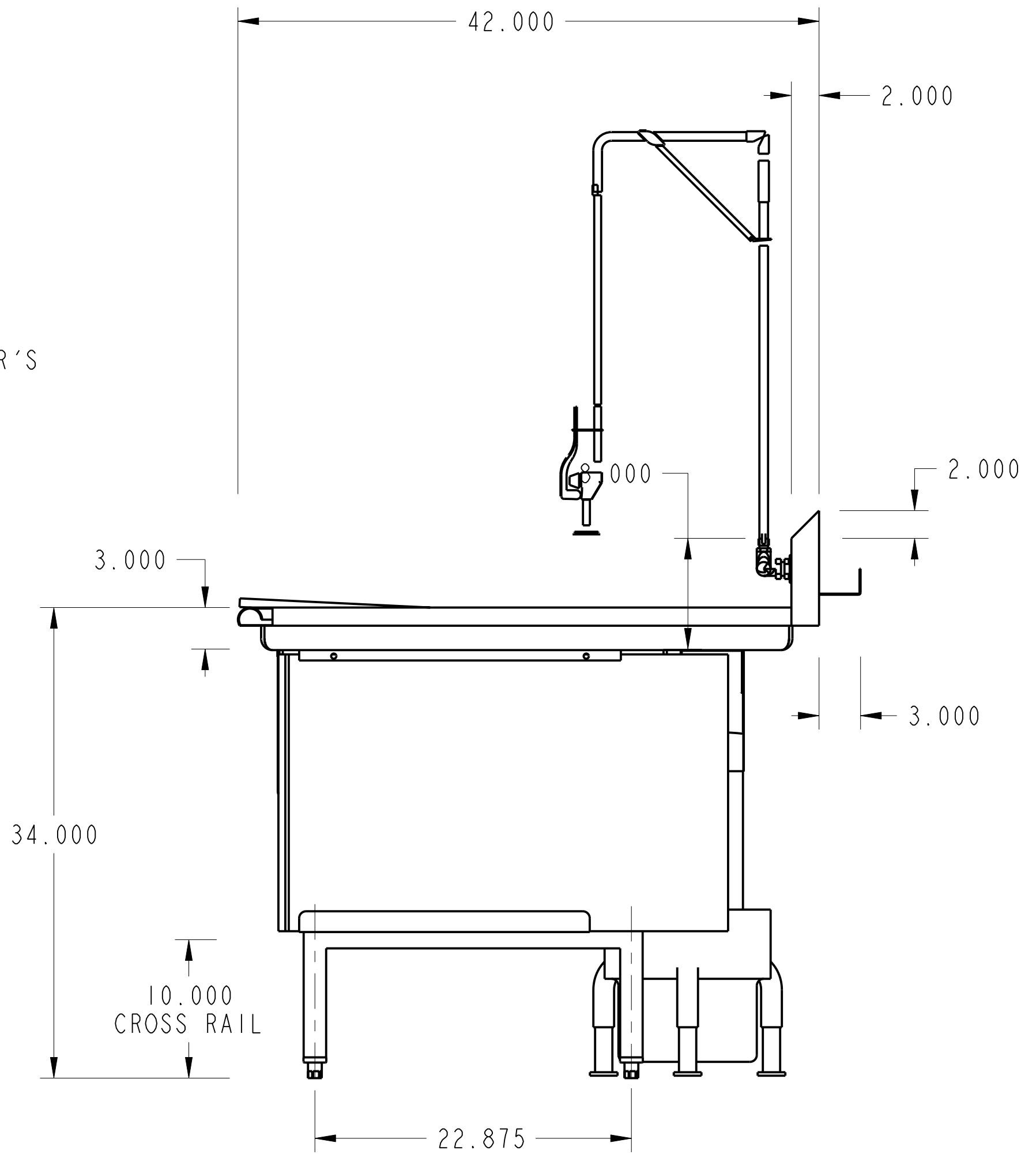

NO.	DATE	REVISIONS	BY
ASSEM		FFPS-106	



THIS DRAWING IS THE PROPERTY OF AMTEKCO INDUSTRIES, INC., AND IS TO REMAIN IN THE POSSESSION OF OUR REPRESENTATIVE UNLESS PERMISSION IS GIVEN BY AMTEKCO INDUSTRIES, INC., AND MUST BE RETURNED WHEN REQUESTED.