

PURCHASED ITEMS

KEY	DESCRIPTION	QTY.	U/M	INV. CODE	VENDOR NAME	PART/MODEL NUMBER	PART TYPE
I	DUO BASKET DRAIN, E38-1010	1	EA	BO	COMPONENT	E38-1010_	ASSEMBLY

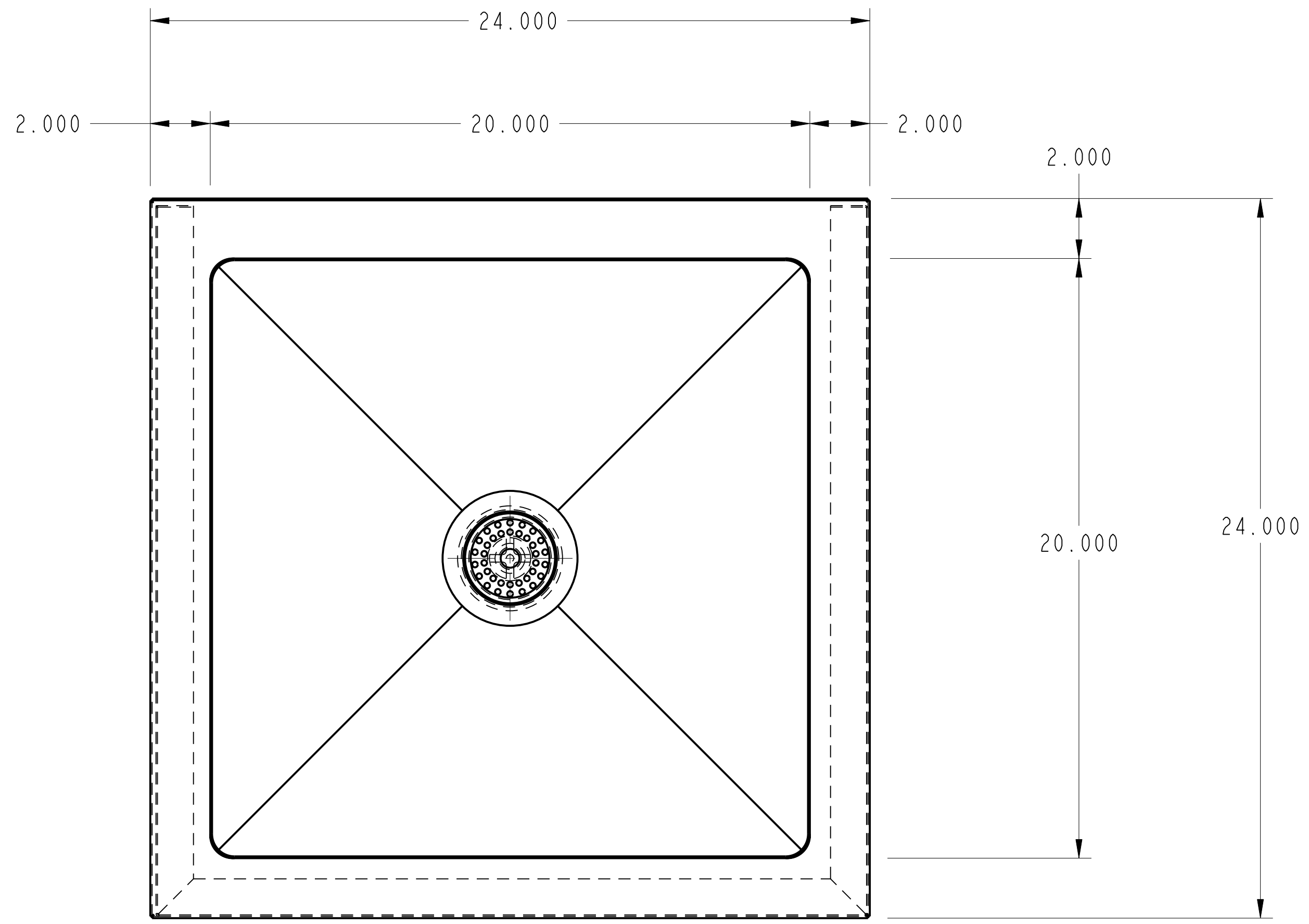

TOP: 16 GA. STN/STL ALL WELDED CONSTRUCTION w/ INTEGRAL 2" BACK SPLASH.

SINKS: 16 GA. STN/STL ALL WELDED CONSTRUCTION. ALL INTERIOR CORNERS TO BE COVERED TO A 3/4" RAD. WITH SPHERICAL INTERSECTIONS. BOTTOM TO BE CREASE TO OPENING FOR LEVER ACTION WASTE AS SHOWN.

SKIRT: 18 GA. STN/STL ALL WELDED CONSTRUCTION

NOTES: ALL STN/STL TO BE TYPE 300 SERIES  
ALL STN/STL TO BE POLISHED TO A NO. 5 FINISH.  
ALL UNEXPOSED WELDS TO BE COVERED w/ ALUMINIUM PAINT  
ALL METAL EDGES AND CORNERS TO BE FILED SMOOTH.

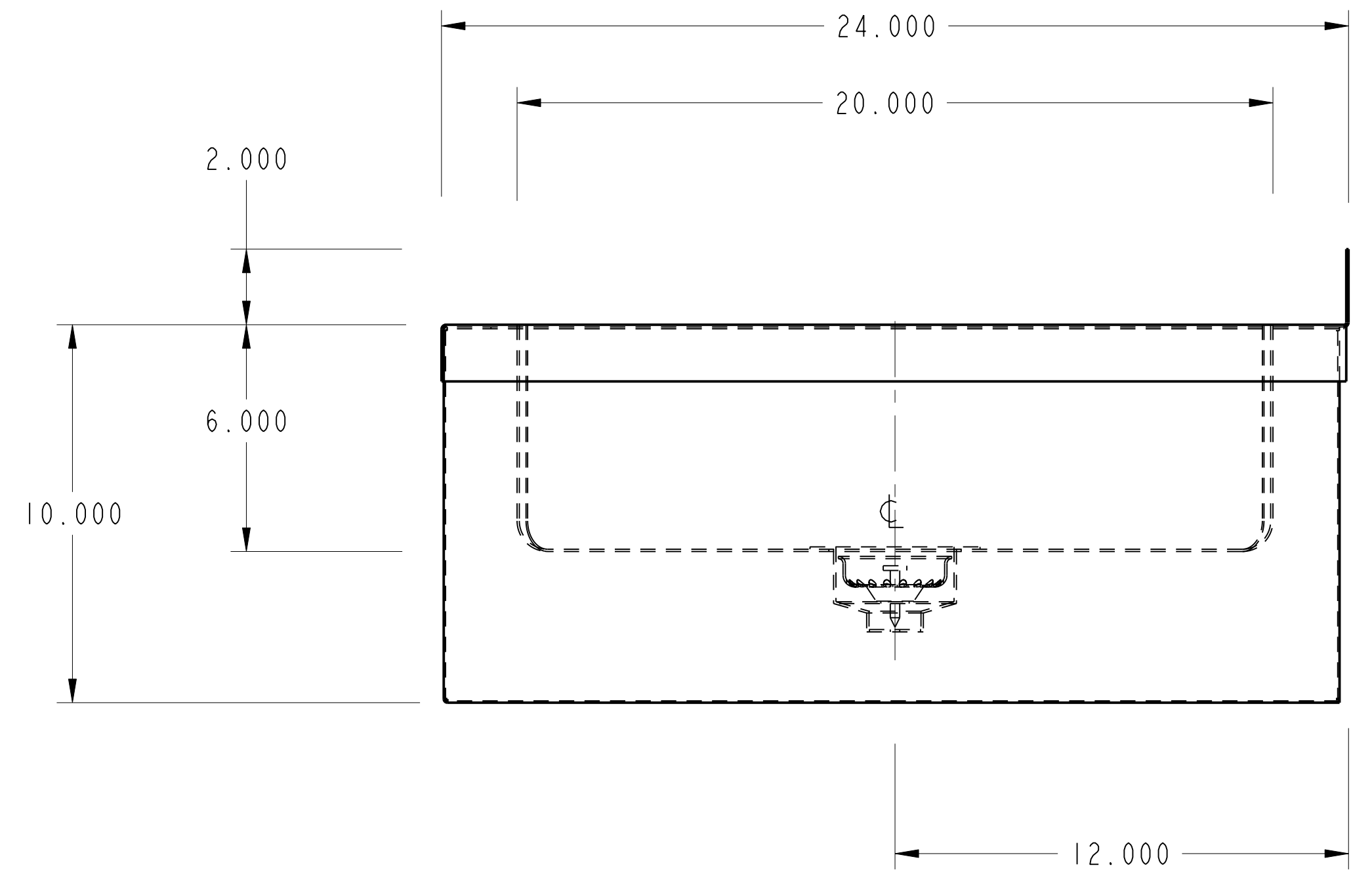
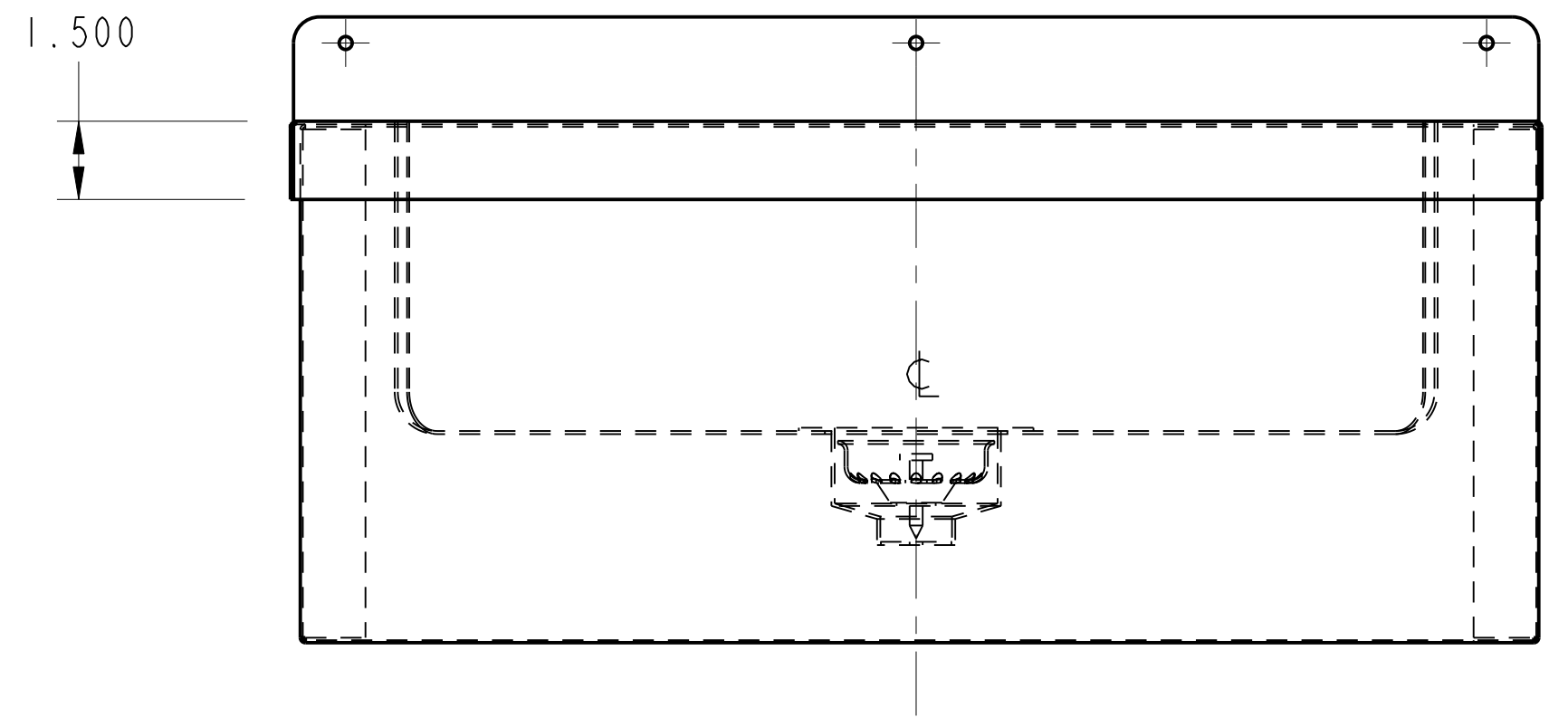
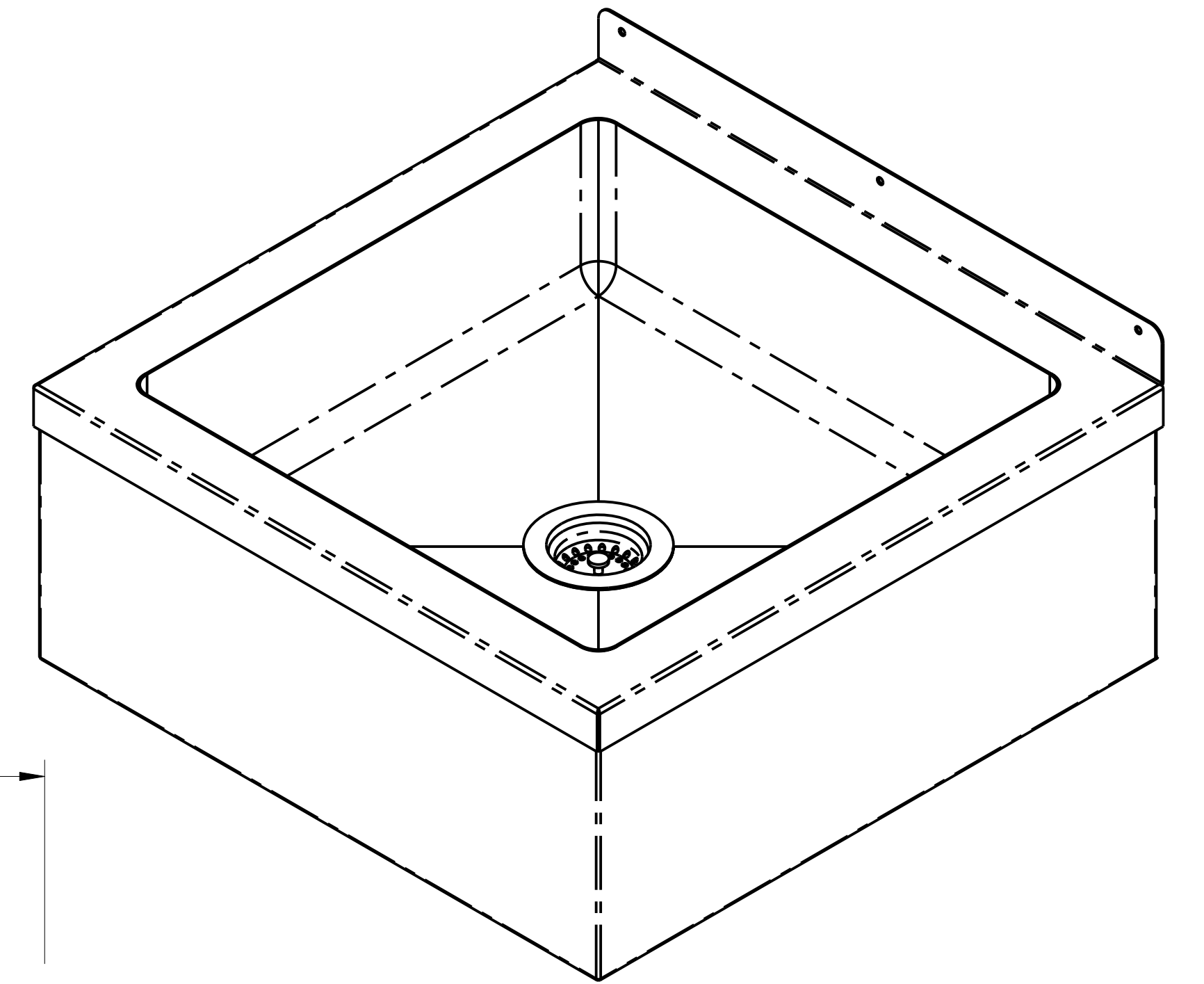

NO.	DATE	REVISIONS	BY
ASSEM		MOP-2424	

