

PURCHASED ITEMS

KEY	DESCRIPTION	QTY.	U/M	INV. CODE	VENDOR NAME	PART/MODEL NUMBER	PART TYPE
1	DUO BASKET DRAIN, E38-1010	1	EA	BO	COMPONENT	E38-1010	ASSEMBLY

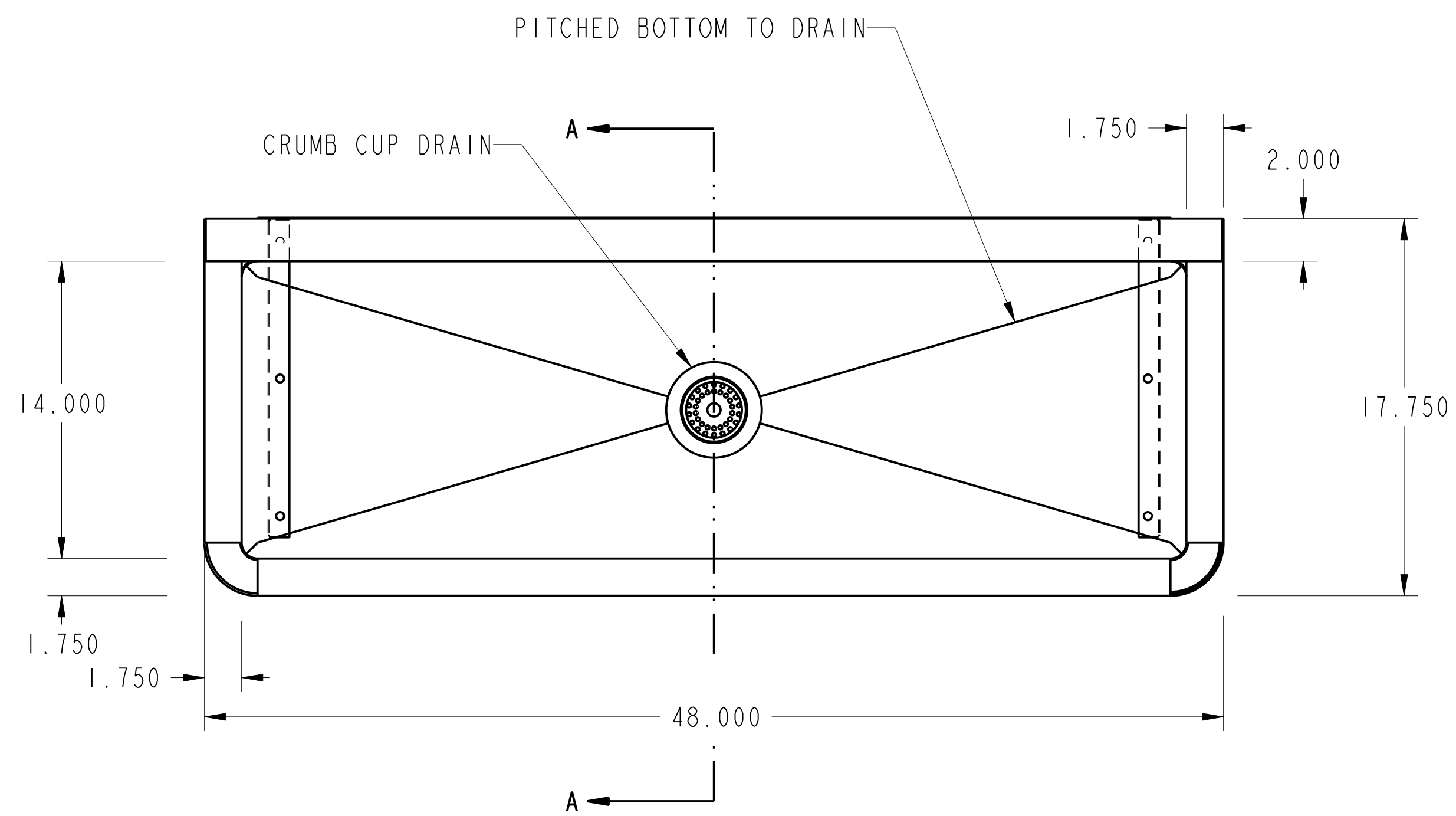

TOP: 16 GA S/S ALL WELDED CONSTRUCTION W/ INTEGRAL 10" HIGH BACKSPLASH ALL HORIZONTAL AND VERTICAL CORNERS TO BE COVERED TO 3/4" RAD. WITH INTEGRAL SINK

BRACKET : 16 GA S/S WELDED TO THE TOP

NOTES: ALL S/S TO BE TYPE 300 SERIES.
ALL S/S TO BE POLISHED TO NO. 3 FINISH
ALL UNEXPOSED WELDS TO BE COVERED W/ ALUMINUM PAINT.
ALL METAL EDGES TO BE FILED SMOOTH.

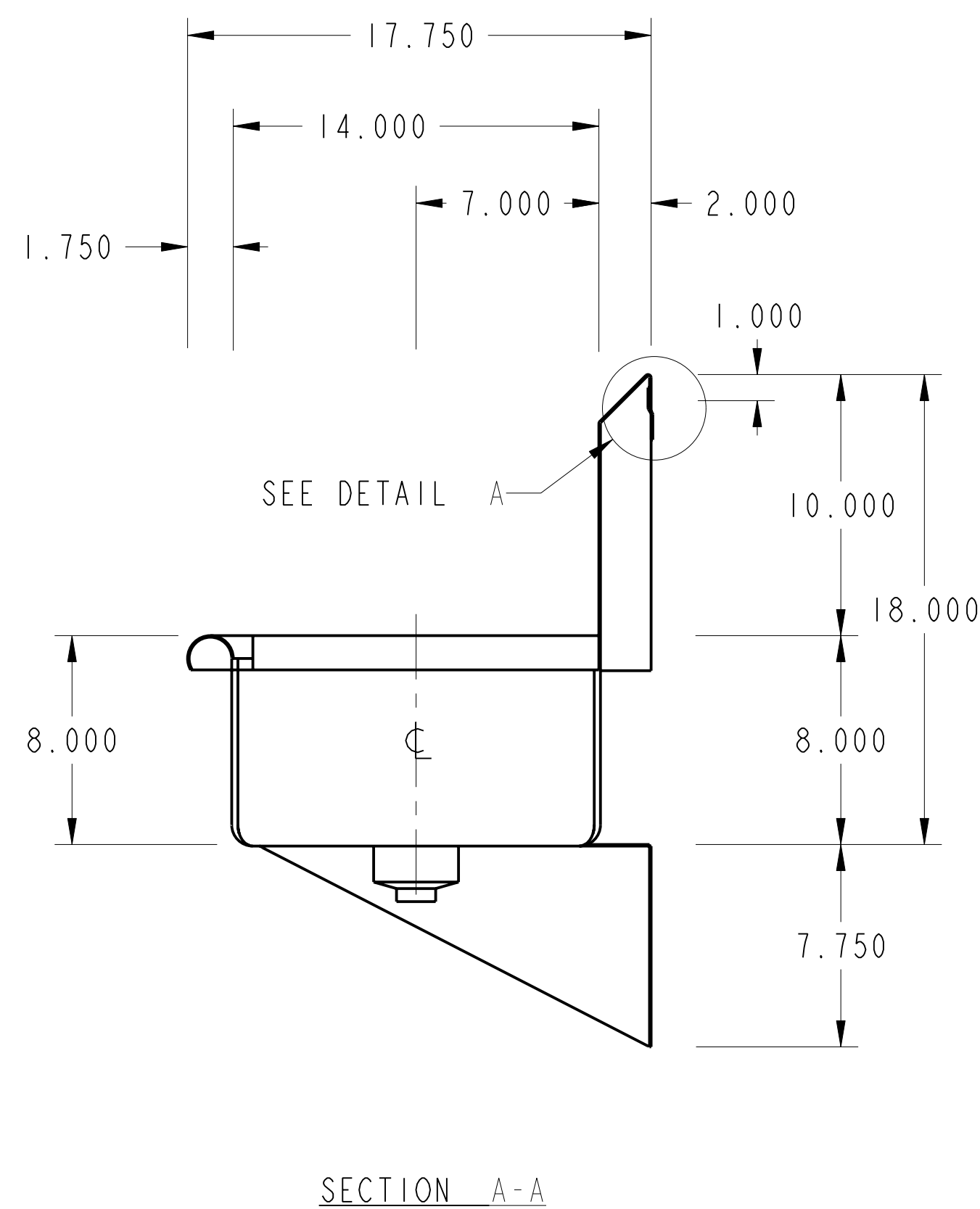
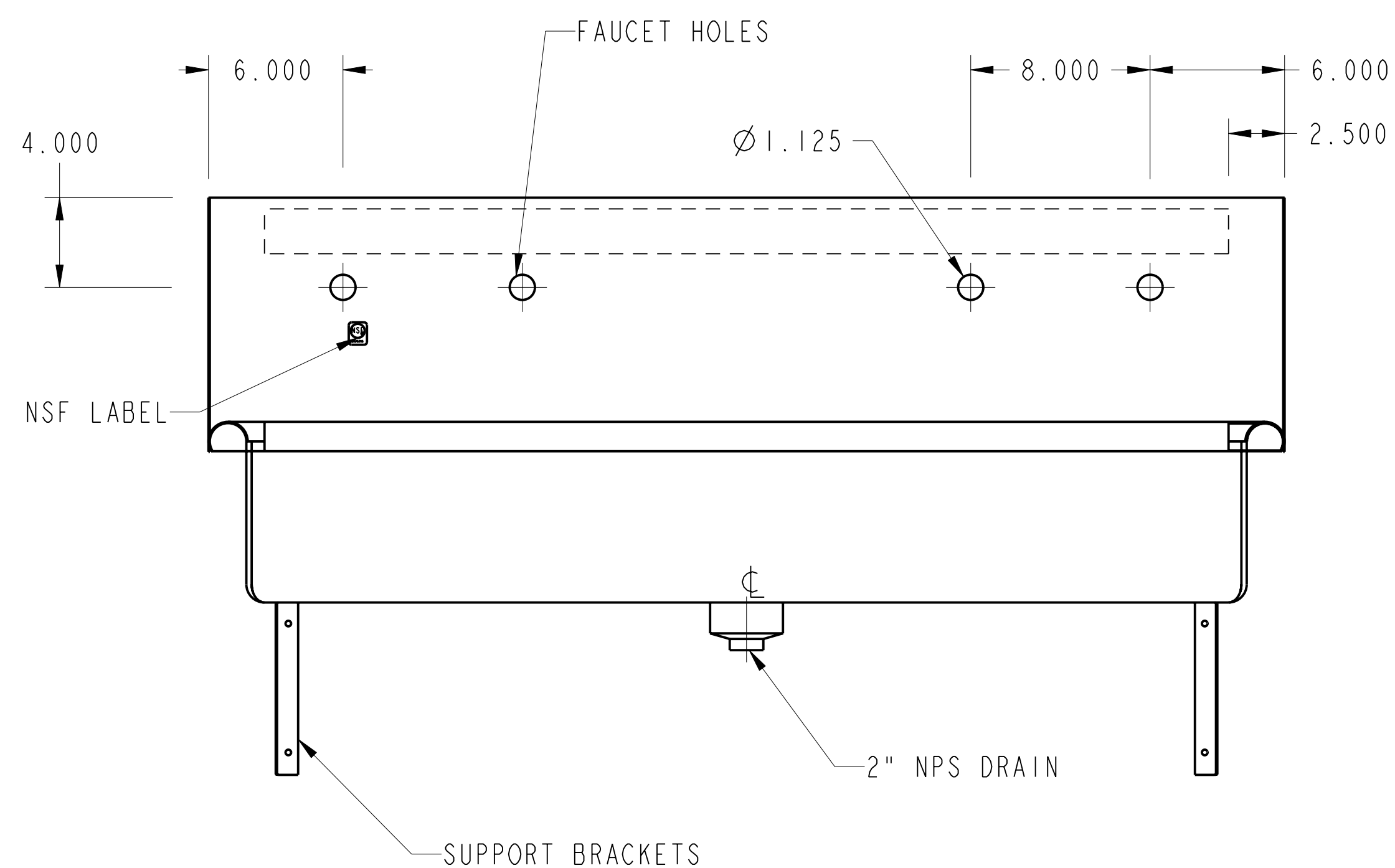
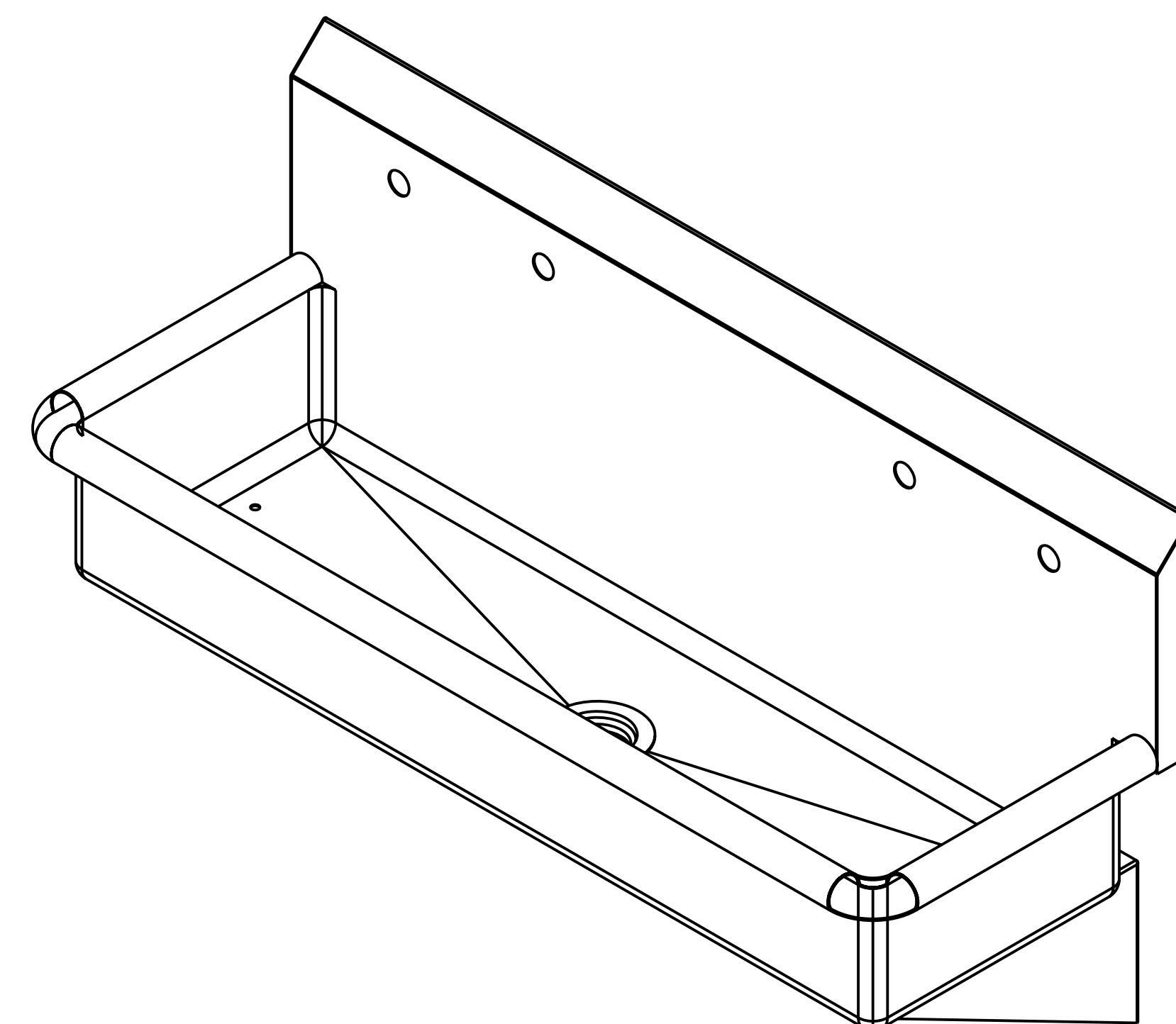
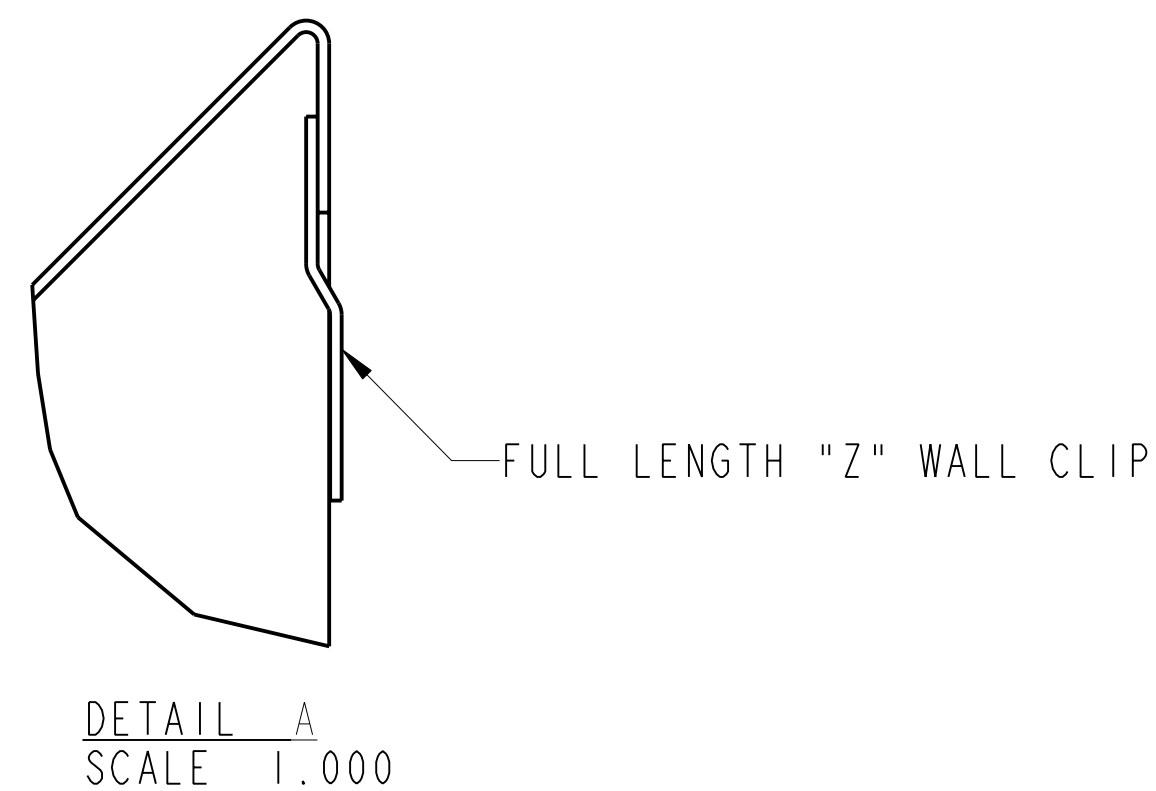

NO.	DATE	REVISIONS	BY
ASSEM		MSWS-48	



AMTEKCO INDUSTRIES, INC.

MANUFACTURERS OF QUALITY PRODUCTS FOR THE FOOD MARKETING INDUSTRY
1875 S. HIGH ST. COLUMBUS, OHIO 43207
(614)228-6590 Fax (614)443-4807

AMTEKCO

48" X 17 3/4" X 18" 1-COMP SINK

APPROVED BY	CKD BY	DATE	SCALE
		05-Sep-06	0.188
DATE	CODE	DRAWING No.	REV.

MSWS-48

THIS DRAWING IS THE PROPERTY OF AMTEKCO INDUSTRIES, INC., AND IS TO REMAIN IN THE POSSESSION OF OUR REPRESENTATIVE UNLESS PERMISSION IS GIVEN BY AMTEKCO INDUSTRIES, INC., AND MUST BE RETURNED WHEN REQUESTED.