

PURCHASED ITEMS

KEY	DESCRIPTION	QTY.	U/M	INV. CODE	VENDOR NAME	PART/MODEL NUMBER	PART TYPE
1	DUO BASKET DRAIN, E38-1010	1	EA	BI	COMPONENT	E38-1010	ASSEMBLY

SINK: 16 GA. STN/STL ALL WELDED CONSTRUCTION w/ INTEGRAL 10" BACK. ALL HORIZONTAL AND VERTICAL CORNERS TO BE COVERED TO A 3/4" RADIUS WITH SPHERICAL INTERSECTIONS. SINKS TO BE WELDED INTEGRAL AS SHOWN. BOTTOM TO PITCH 1/4" PER FOOT TO DRAIN OPENING

WALL MOUNT BRACKETS: 16 GA. STN/STL W/ 3/8" STUD HOLES TO FASTEN TO SINK BOTTOM AND WALL. FULL LENGTH STN/STL "Z" CLIP SUPPLIED WITH SINK.

NOTES: ALL STN/STL TO BE 300 SERIES.
ALL STN/STL TO BE POLISHED TO A NO. 5 FINISH.
ALL UNEXPOSED WELDS TO BE COVERED w/ ALUMINUM PAINT.
ALL METAL EDGES AND CORNERS TO BE FILED SMOOTH.

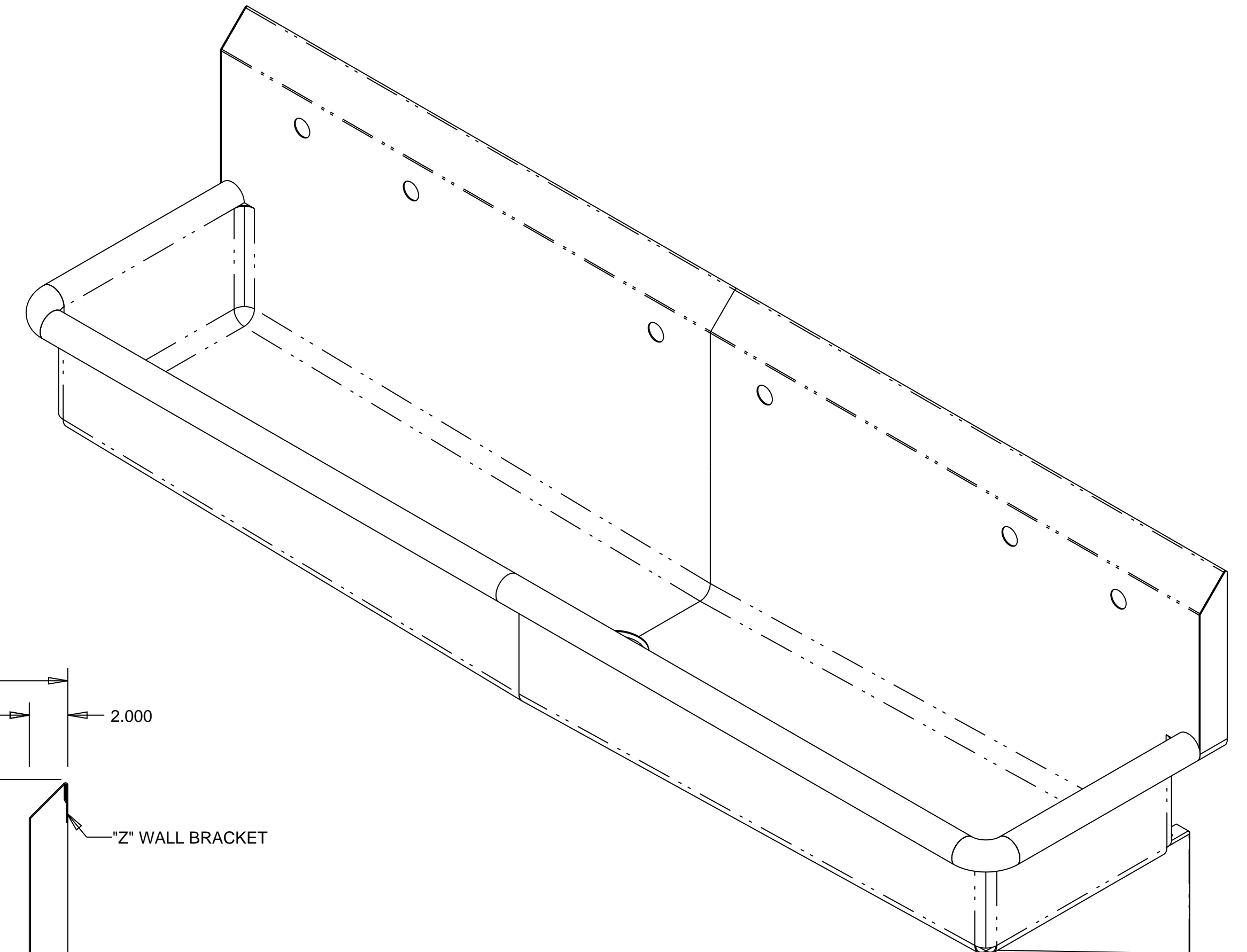
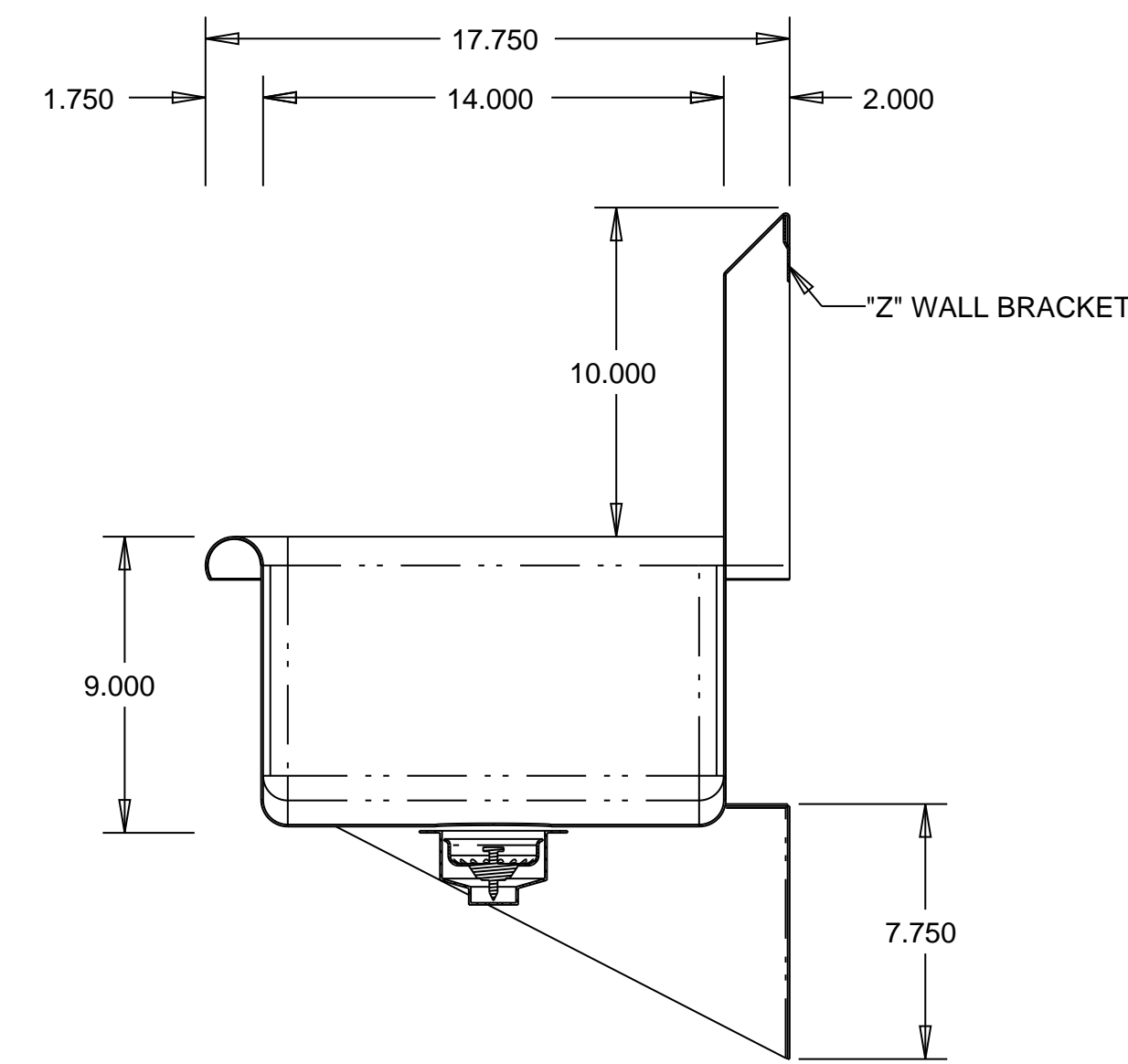
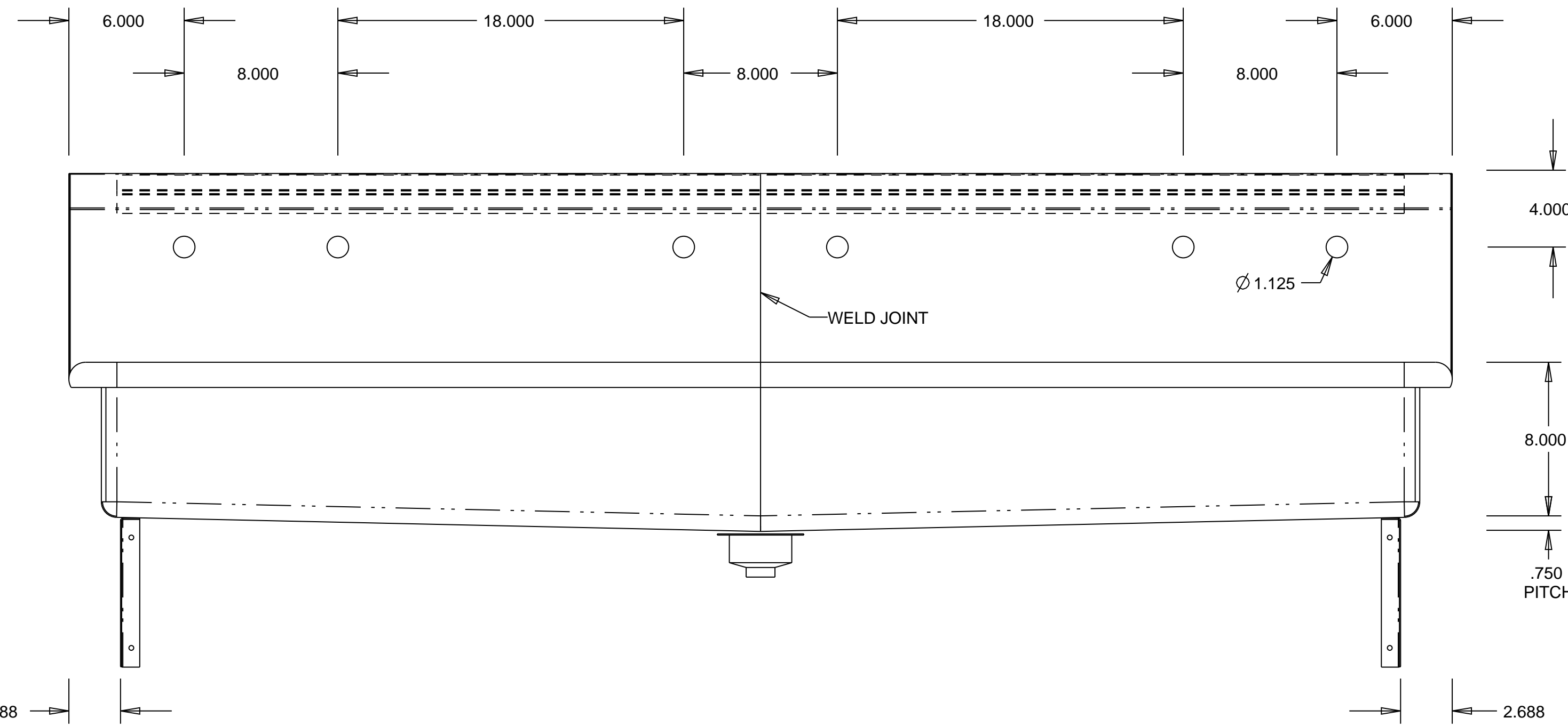
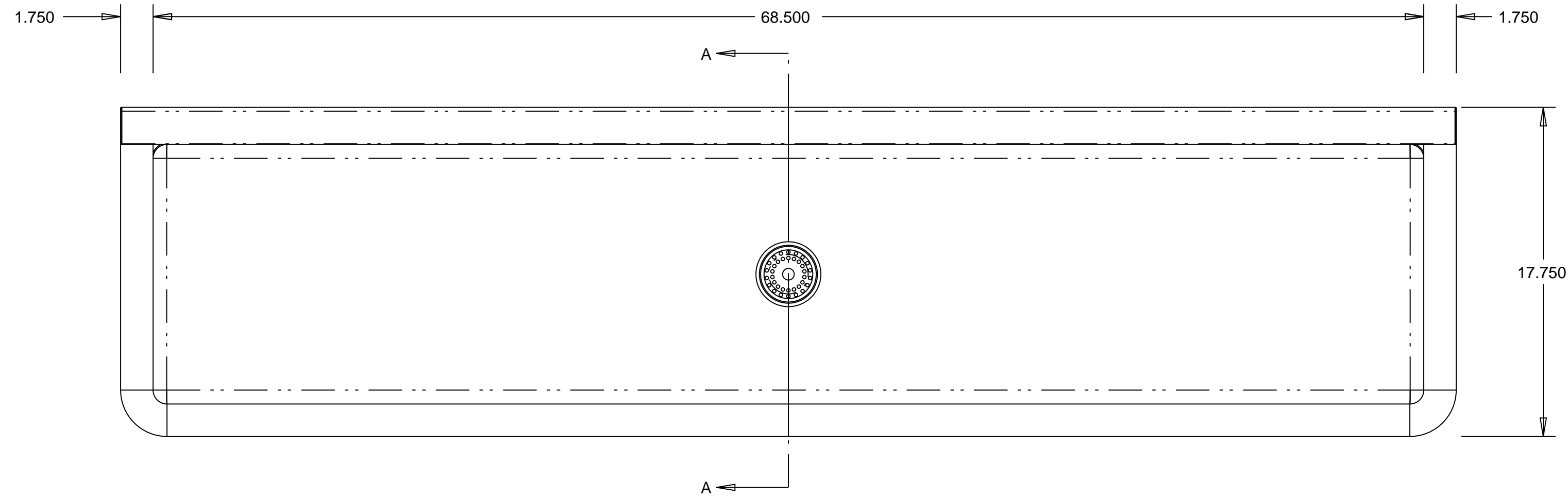

NO.	DATE	REVISIONS	BY
ASSEM		MSWS-72	



PRO

THIS DRAWING IS THE PROPERTY OF AMTEKCO INDUSTRIES INC. AND IS TO REMAIN IN THE POSSESSION OF OUR REPRESENTATIVE UNLESS PERMISSION IS GIVEN BY AMTEKCO INDUSTRIES INC. AND MUST BE RETURNED WHEN REQUESTED.