

PURCHASED ITEMS

KEY	DESCRIPTION	QTY.	U/M	INV. CODE	VENDOR NAME	PART/MODEL NUMBER	PART TYPE
1	DUO BASKET DRAIN, E38-1010	1	EA	BI	COMPONENT	E38-1010	ASSEMBLY

SINK: 16 GA. STN/STL ALL WELDED CONSTRUCTION W/ INTEGRAL 10" BACK. ALL HORIZONTAL AND VERTICAL CORNERS TO BE COVERED TO A 3/4" RADIUS WITH SPHERICAL INTERSECTIONS. SINKS TO BE WELDED INTEGRAL AS SHOWN. BOTTOM TO PITCH 1/4" PER FOOT TO DRAIN OPENING

WALL MOUNT BRACKETS: 16 GA. STN/STL W/ 3/8" STUD HOLES TO FASTEN TO SINK BOTTOM AND WALL. FULL LENGTH STN/STL "Z" CLIP SUPPLIED WITH SINK.

NOTES: ALL STN/STL TO BE 300 SERIES.
ALL STN/STL TO BE POLISHED TO A NO. 5 FINISH.
ALL UNEXPOSED WELDS TO BE COVERED W/ ALUMINUM PAINT.
ALL METAL EDGES AND CORNERS TO BE FILED SMOOTH.

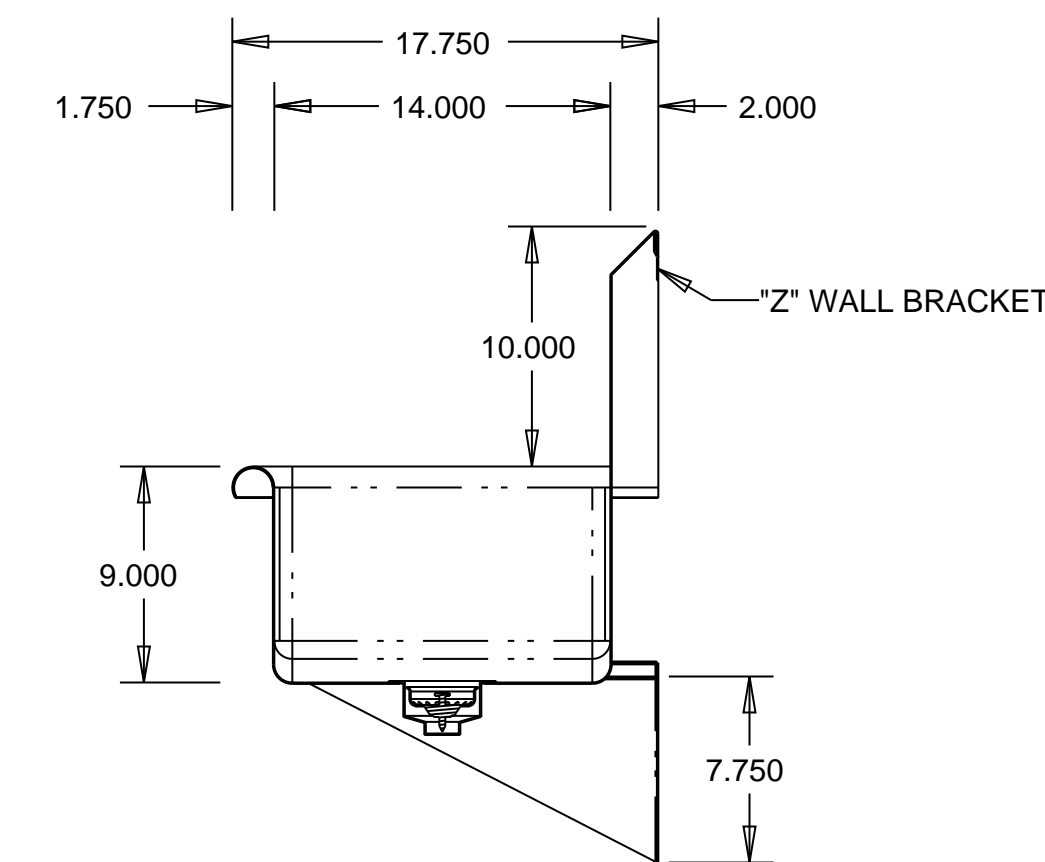
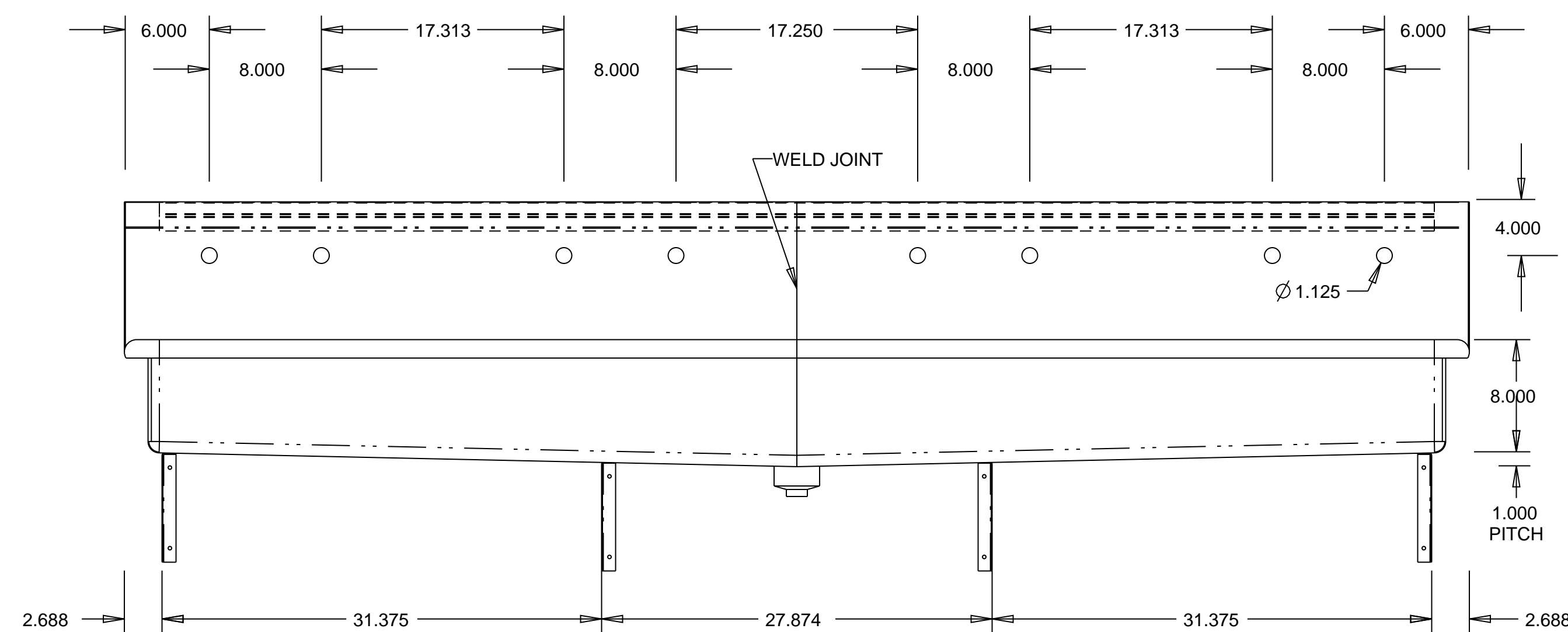
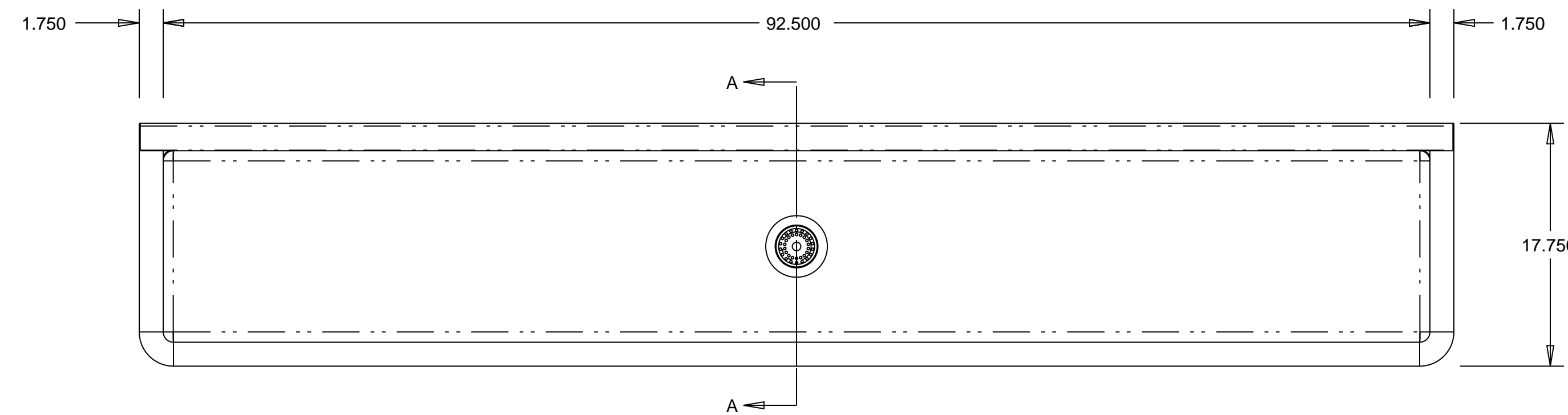

SECTION A-A

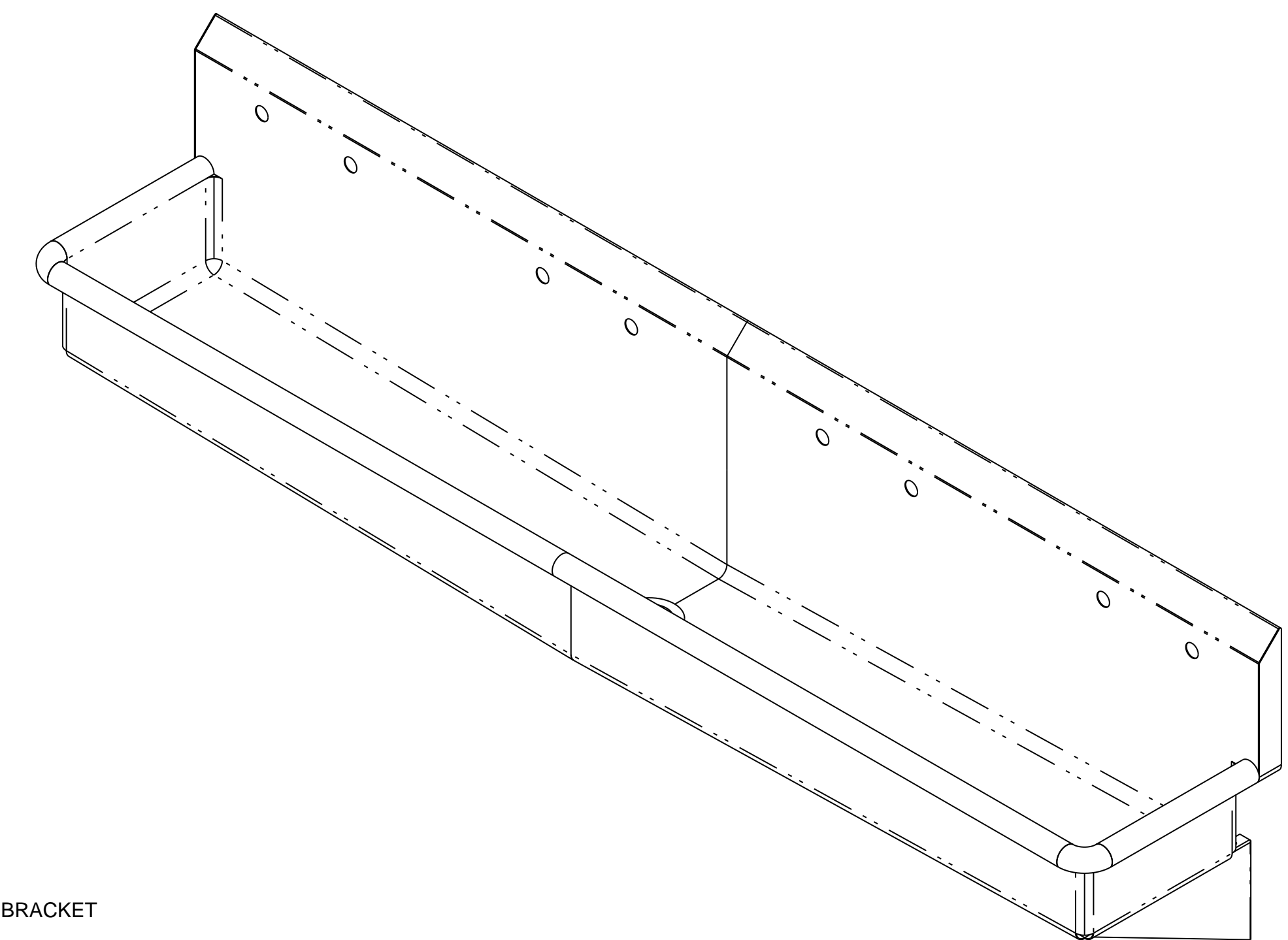

NO.	DATE	REVISIONS	BY

ASSEM MSWS-96



AMTEKCO INDUSTRIES, INC.

MANUFACTURERS OF QUALITY PRODUCTS FOR THE FOOD MARKETING INDUSTRY
1205 REFUGEE ROAD COLUMBUS, OHIO 43207
(614) 228-6590 Fax (614) 737-8016

AMTEKCO

96" LONG MULTIPLE STATION WASH SINK (MSWS-96)

APPROVED BY	CKD BY	DATE	SCALE
		07-May-07	0.125
DATE	CODE	DRAWING No.	REV.

MSWS-96