

PURCHASED ITEMS

| KEY | DESCRIPTION | QTY. | U/M | INV. CODE | VENDOR NAME | PART/MODEL NUMBER | PART TYPE |
|-----|---|------|-----|-----------|----------------------|-------------------|-----------|
| 1 | LEG GUSSET | 4 | EA | BI | COMPONENT | A18-0406 | PART |
| 2 | S/S ADJUSTABLE BULLET FOOT | 6 | EA | BI | COMPONENT | A10-0851 | PART |
| 3 | S/S LEG SOCKET | 2 | EA | BI | COMPONENT | A18-0206 | PART |
| 4 | LA WASTE W/OVERFLOW ASSEMBLY, FLAT STRAINER | 3 | EA | BI | COMPONENT | D50-7215 | PART |
| 5 | ATMOSPHERIC VACUUM BREAKER | 1 | EA | BI | FISHER | 3990 | PART |
| 6 | C5-L-SK-CR208/60/3 | 1 | EA | BI | MASTER DISPOSER INC. | C5-L-SK-CR | PART |
| 7 | CRATE RACK | 1 | EA | BI | QUADRATECH | AMT9750P001 | PART |

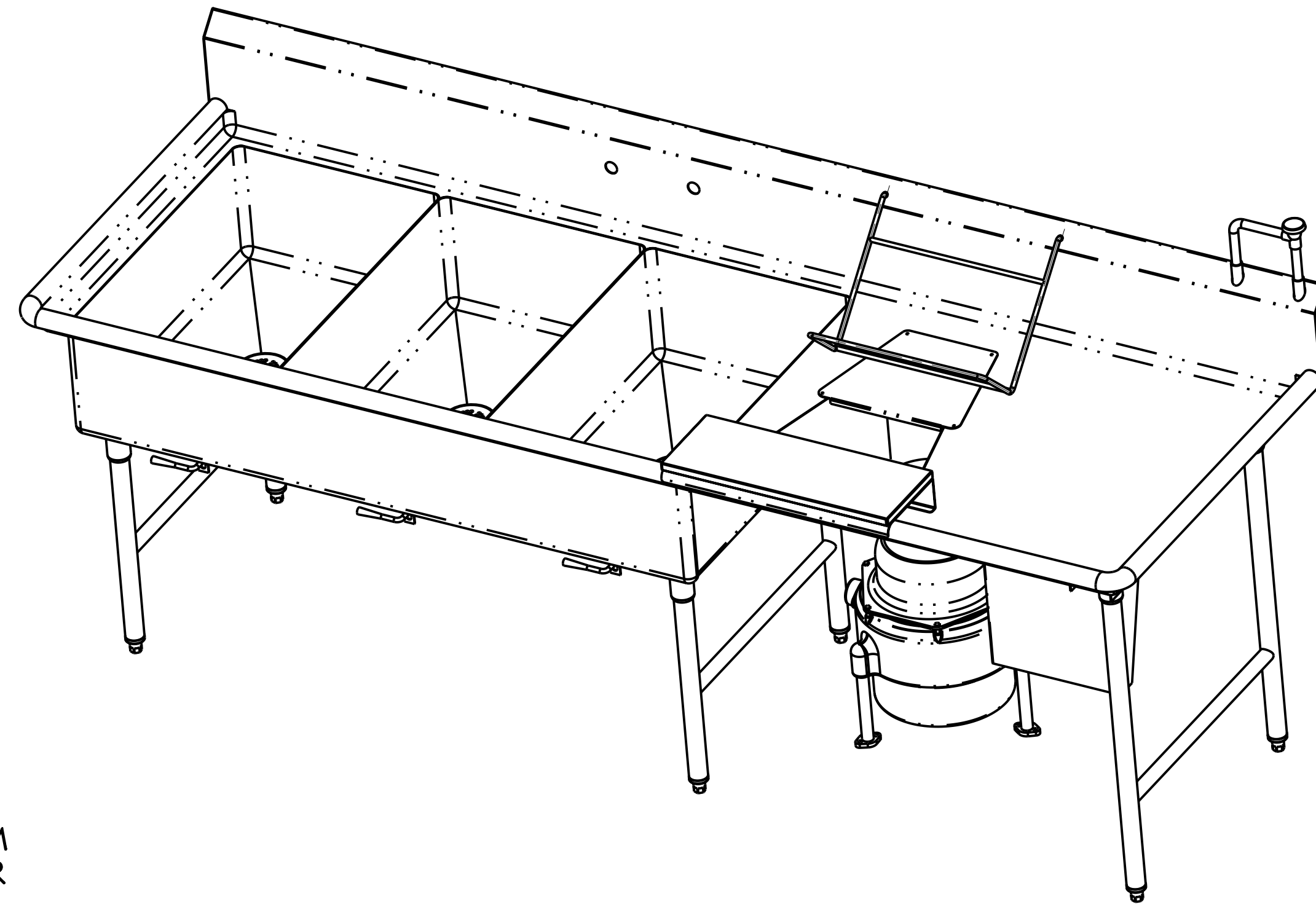

- TOP: 16 GA. STN/STL ALL WELDED CONSTRUCTION W/ INTEGRAL BACK. ALL HORIZONTAL AND VERTICAL CORNERS TO BE COVERED TO A 3/4" RADIUS. SINKS TO BE WELDED INTEGRAL AS SHOWN.
- SINKS: 16 GA. STN/STL ALL WELDED CONSTRUCTION. ALL INTERIOR CORNERS TO BE COVERED TO A 3/4" RAD. WITH SPHERICAL INTERSECTIONS. BOTTOM TO BE CREASE TO OPENING FOR LEVER ACTION WASTE AS SHOWN.
- CROSSRAILS: 1 1/4" O.D. 16 GA. S/S TUBING FULLY WELDED TO LEGS.
- LEGS: 1 5/8" O.D. 16 GA. STN/STL TUBING HELD IN STN/STL LEG HOLDERS WHICH ARE FULLY WELDED TO REINFORCING PLATE ON UNDER SIDE OF SINK BOWLS.
- FEET: STN/STL ADJUSTABLE BULLET TYPE.
- NOTES: ALL STN/STL TO BE TYPE 304. ALL STN/STL TO BE POLISHED TO A NO. 5 FINISH. ALL UNEXPOSED WELDS TO BE COVERED W/ ALUMINUM PAINT. ALL METAL EDGES AND CORNERS TO BE FILED SMOOTH.

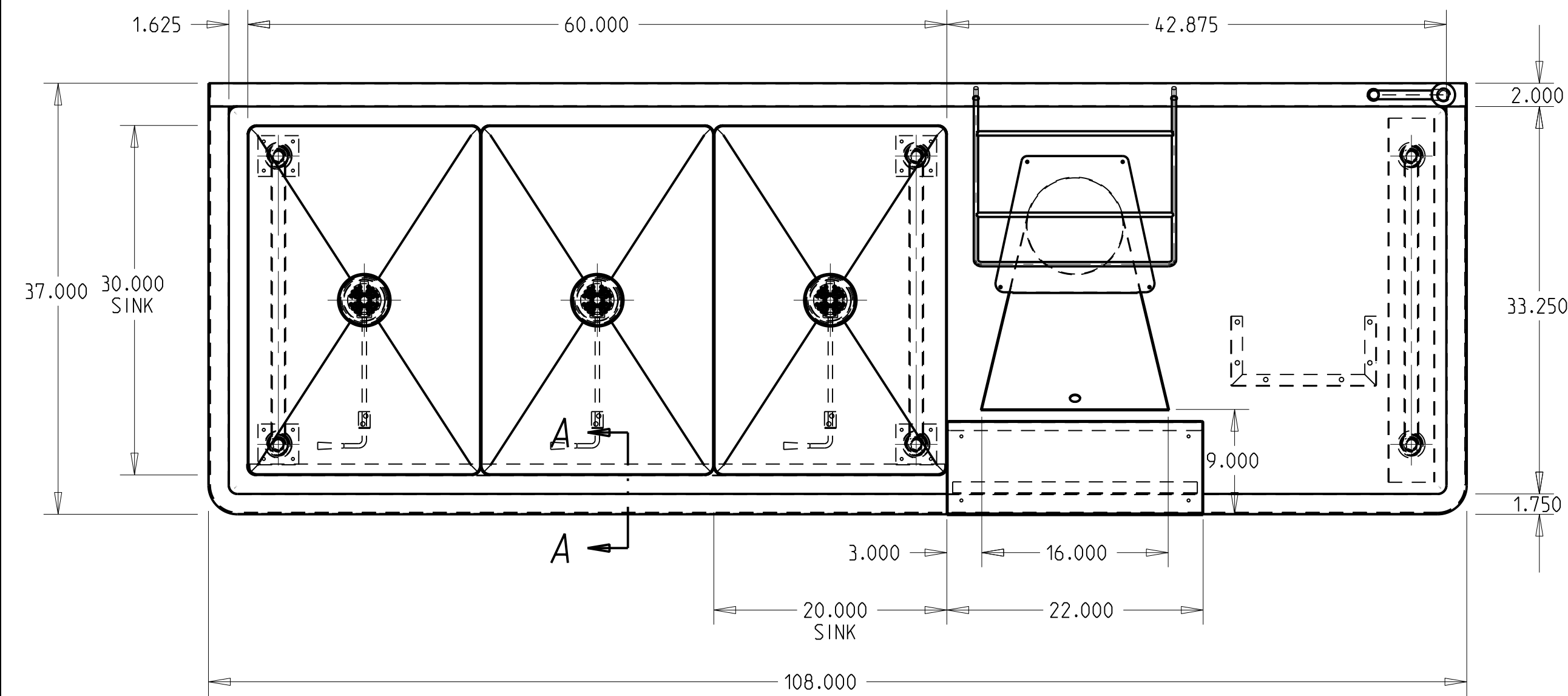
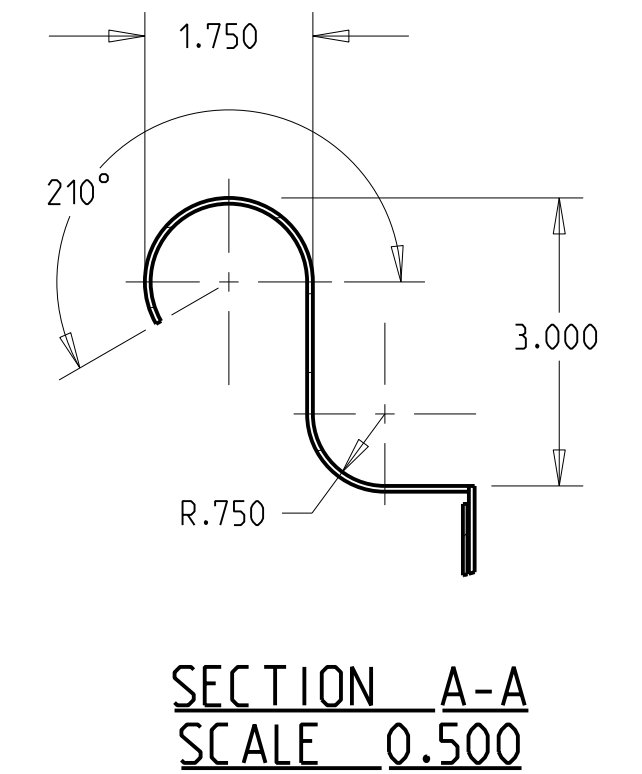
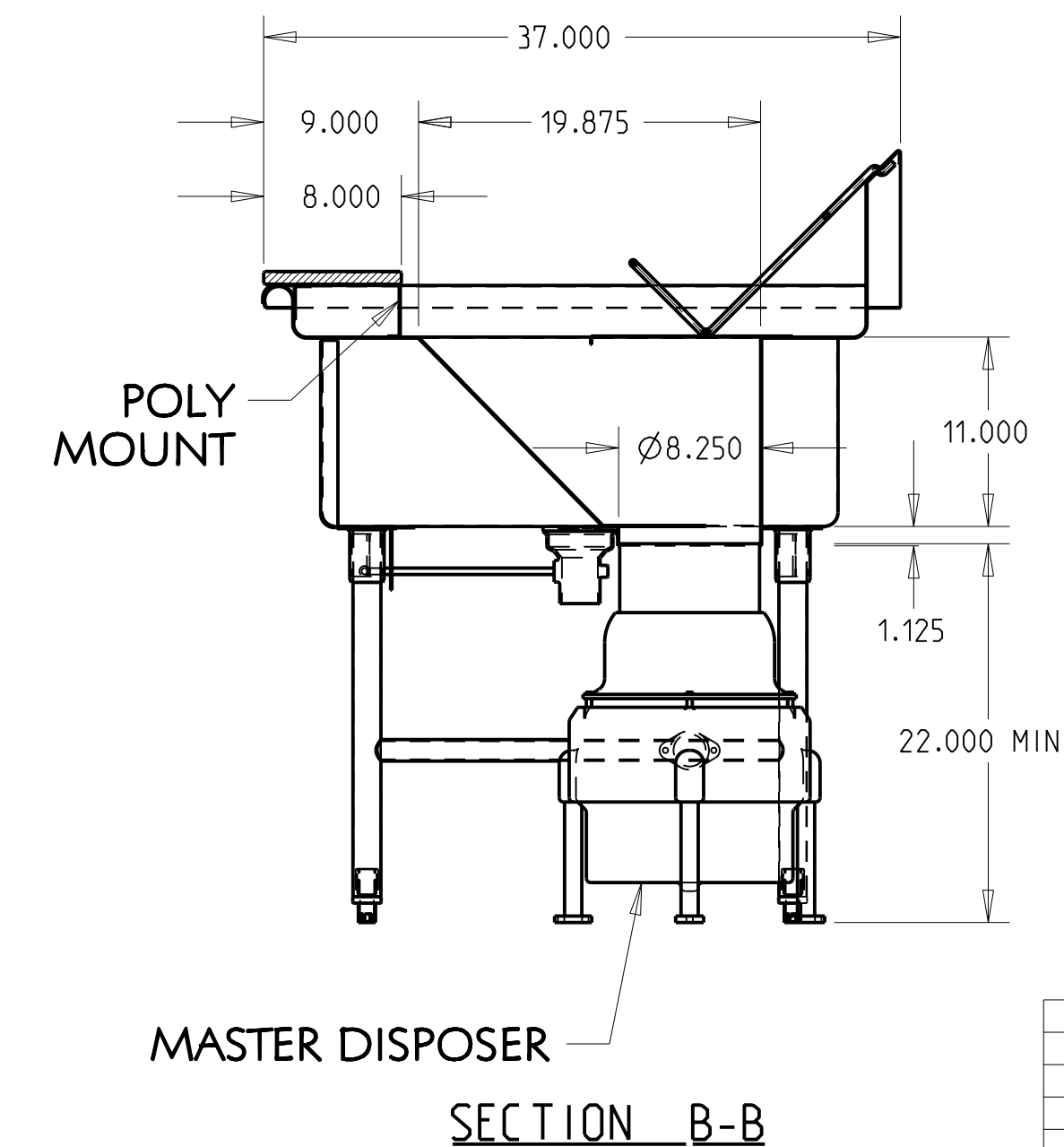
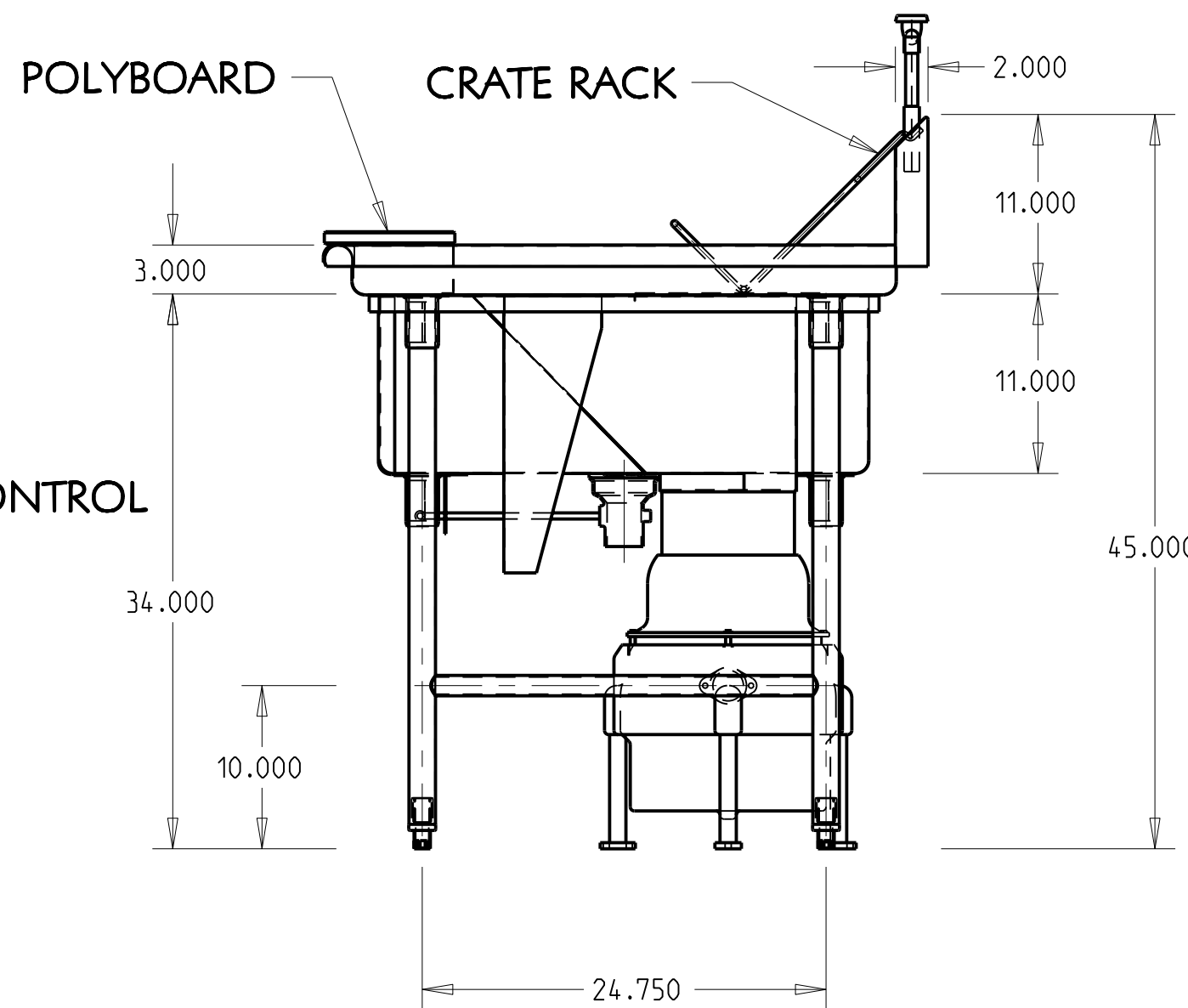
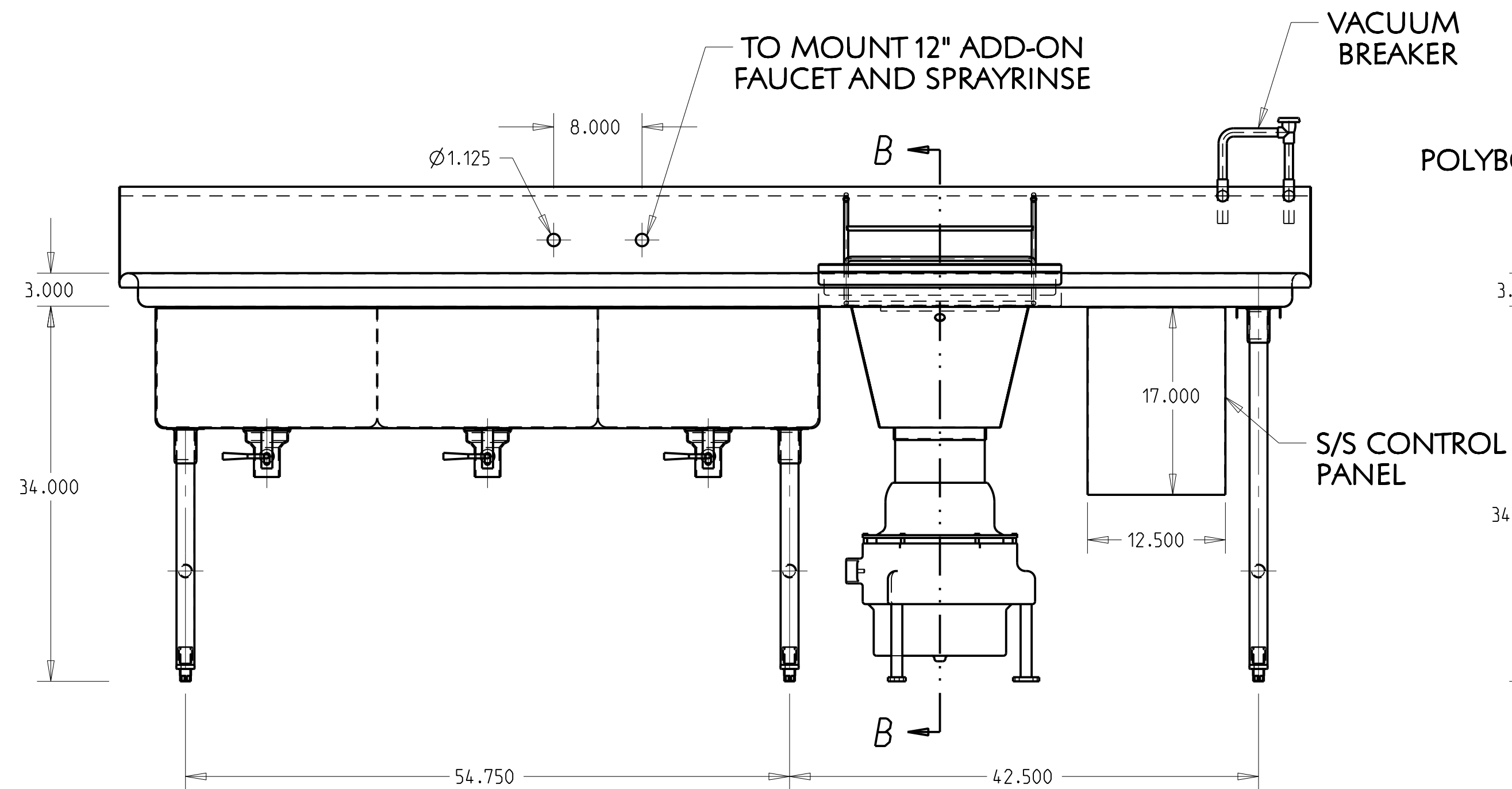

| NO. | DATE | REVISIONS | BY |
|-----|------|-----------|----|
| | | | |
| | | | |
| | | | |
| | | | |
| | | | |
| | | | |
| | | | |
| | | | |
| | | | |



THIS DRAWING IS THE PROPERTY OF AMTEKCO INDUSTRIES, INC. AND IS TO REMAIN IN THE POSSESSION OF OUR REPRESENTATIVE UNLESS PERMISSION IS GIVEN BY AMTEKCO INDUSTRIES, INC. AND MUST BE RETURNED WHEN REQUESTED.