

PURCHASED ITEMS

KEY	DESCRIPTION	QTY.	U/M	INV. CODE	VENDOR NAME	PART/MODEL NUMBER	PART TYPE
1	LEG GUSSET	4	EA	BI	COMPONENT	A18-0406	PART
2	S/S ADJUSTABLE BULLET FOOT	6	EA	BI	COMPONENT	A10-0851	PART
3	S/S LEG SOCKET	2	EA	BI	COMPONENT	A18-0206	PART
4	LA WASTE W/OVERFLOW ASSEMBLY, FLAT STRAINER	2	EA	BI	COMPONENT	D50-7215	PART
5	ATMOSPHERIC VACUUM BREAKER	1	EA	BI	FISHER	3990	PART
6	C5-L-SK-CR208/60/3	1	EA	BI	MASTER DISPOSER INC.	C5-L-SK-CR	PART
7	CRATE RACK	1	EA	BI	QUADRATECH	AMT9750P001	PART

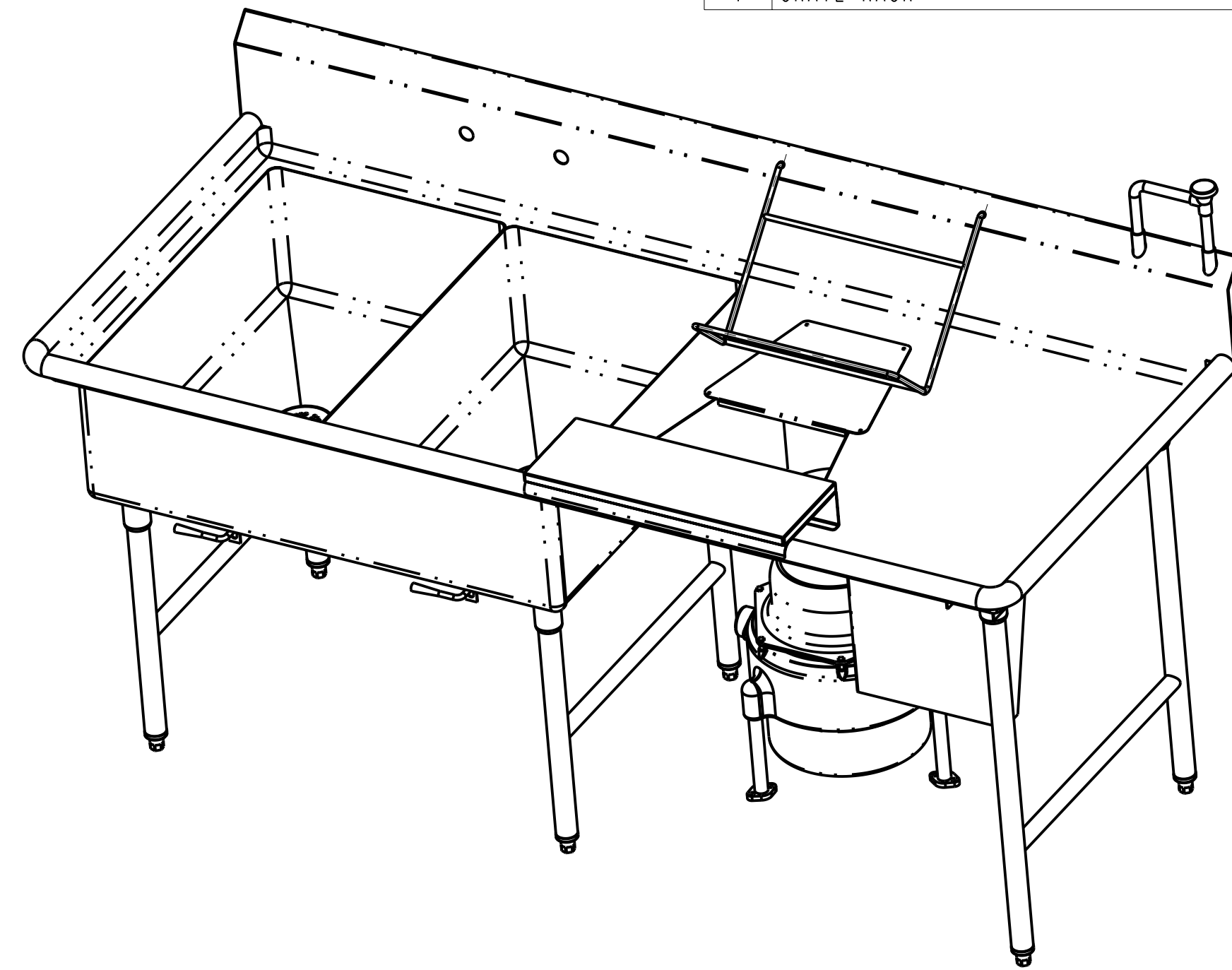

- TOP: 16 GA. STN/STL ALL WELDED CONSTRUCTION w/ INTEGRAL BACK. ALL HORIZONTAL AND VERTICAL CORNERS TO BE COVERED TO A 3/4" RADIUS. SINKS TO BE WELDED INTEGRAL AS SHOWN.
- SINKS: 16 GA. STN/STL ALL WELDED CONSTRUCTION. ALL INTERIOR CORNERS TO BE COVERED TO A 3/4" RAD. WITH SPHERICAL INTERSECTIONS. BOTTOM TO BE CREASE TO OPENING FOR LEVER ACTION WASTE AS SHOWN.
- CROSSRAILS: 1 1/4" O.D. 16 GA. S/S TUBING FULLY WELDED TO LEGS.
- LEGS: 1 5/8" O.D. 16 GA. STN/STL TUBING HELD IN STN/STL LEG HOLDERS WHICH ARE FULLY WELDED TO REINFORCING PLATE ON UNDER SIDE OF SINK BOWLS.
- FEET: STN/STL ADJUSTABLE BULLET TYPE.
- NOTES: ALL STN/STL TO BE TYPE 304. ALL STN/STL TO BE POLISHED TO A NO. 5 FINISH. ALL UNEXPOSED WELDS TO BE COVERED w/ ALUMINUM PAINT. ALL METAL EDGES AND CORNERS TO BE FILED SMOOTH.

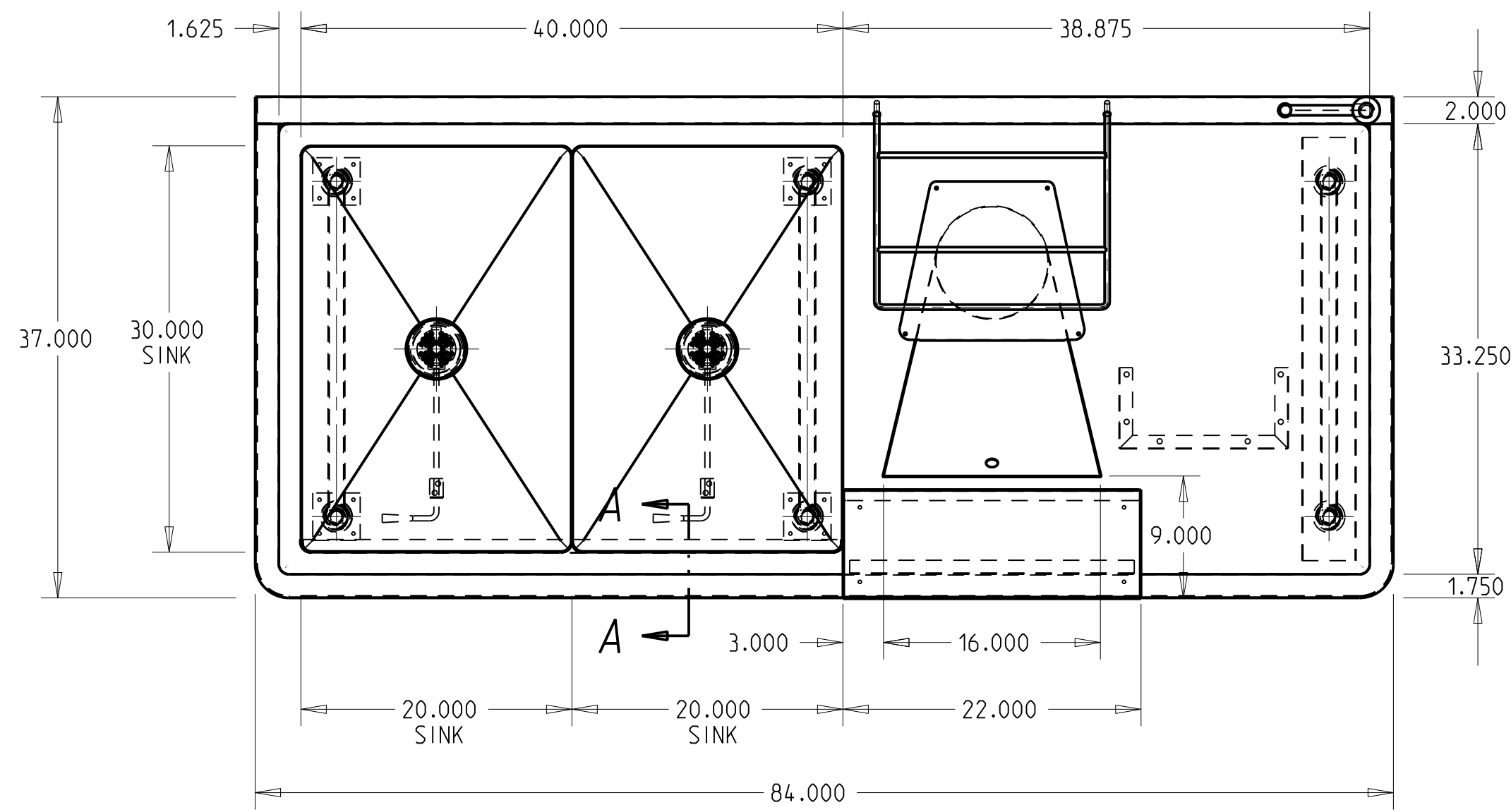
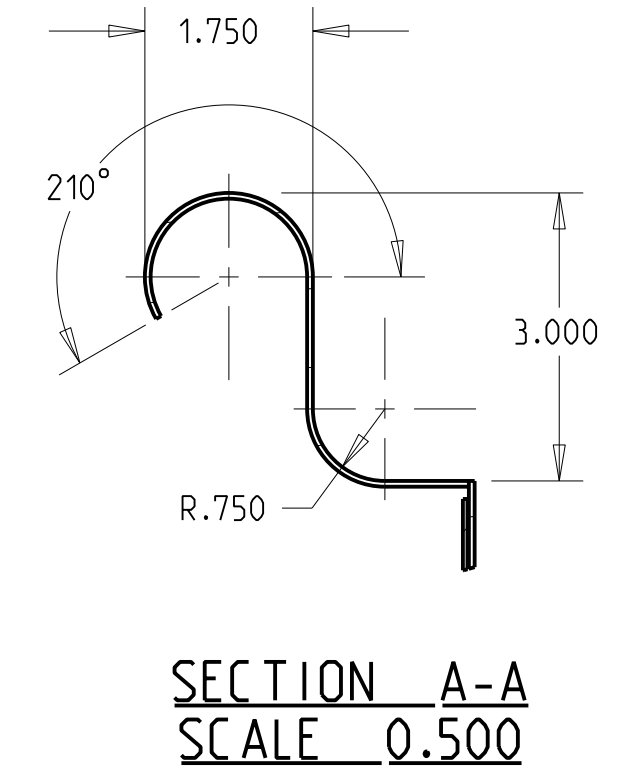
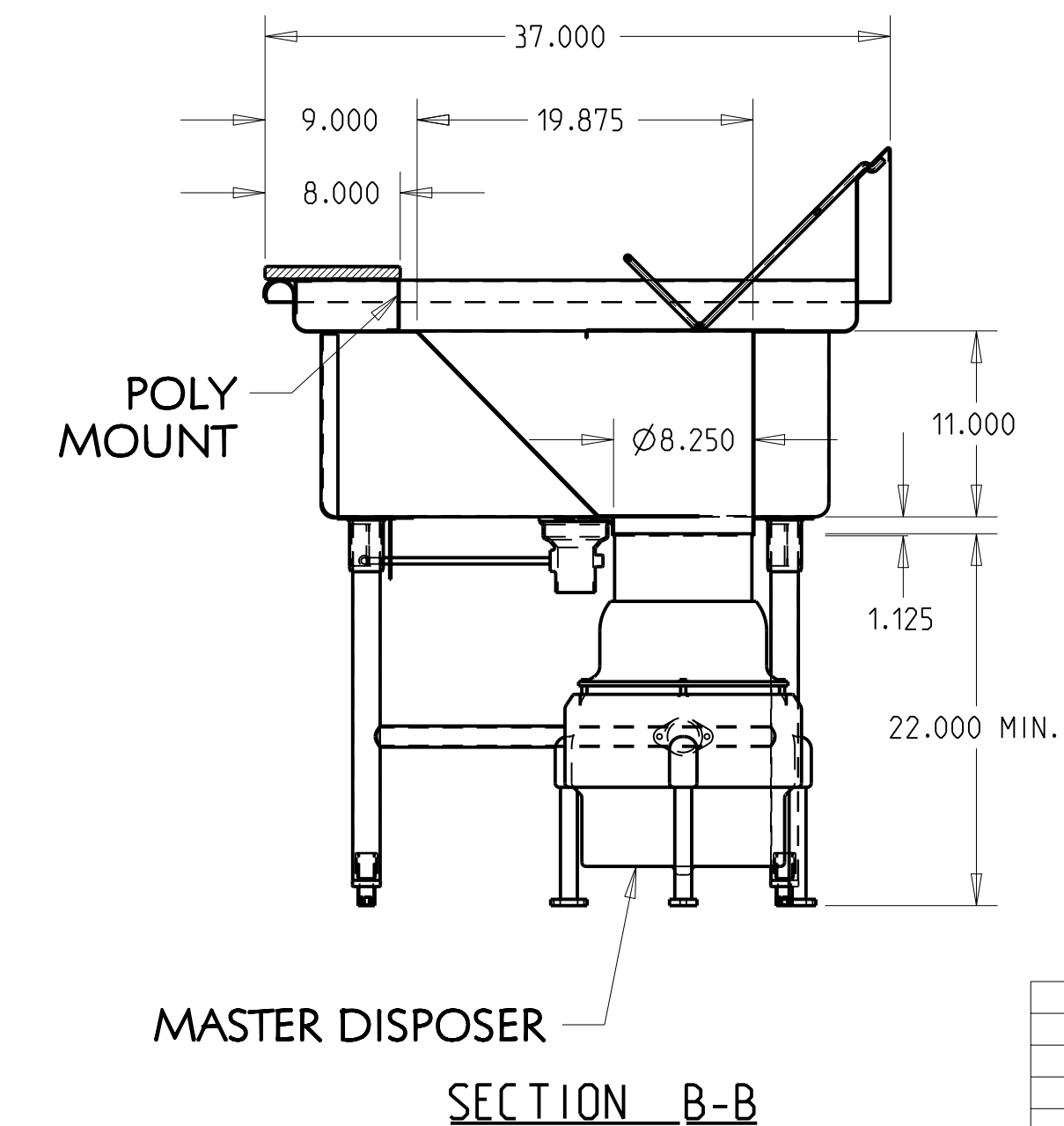
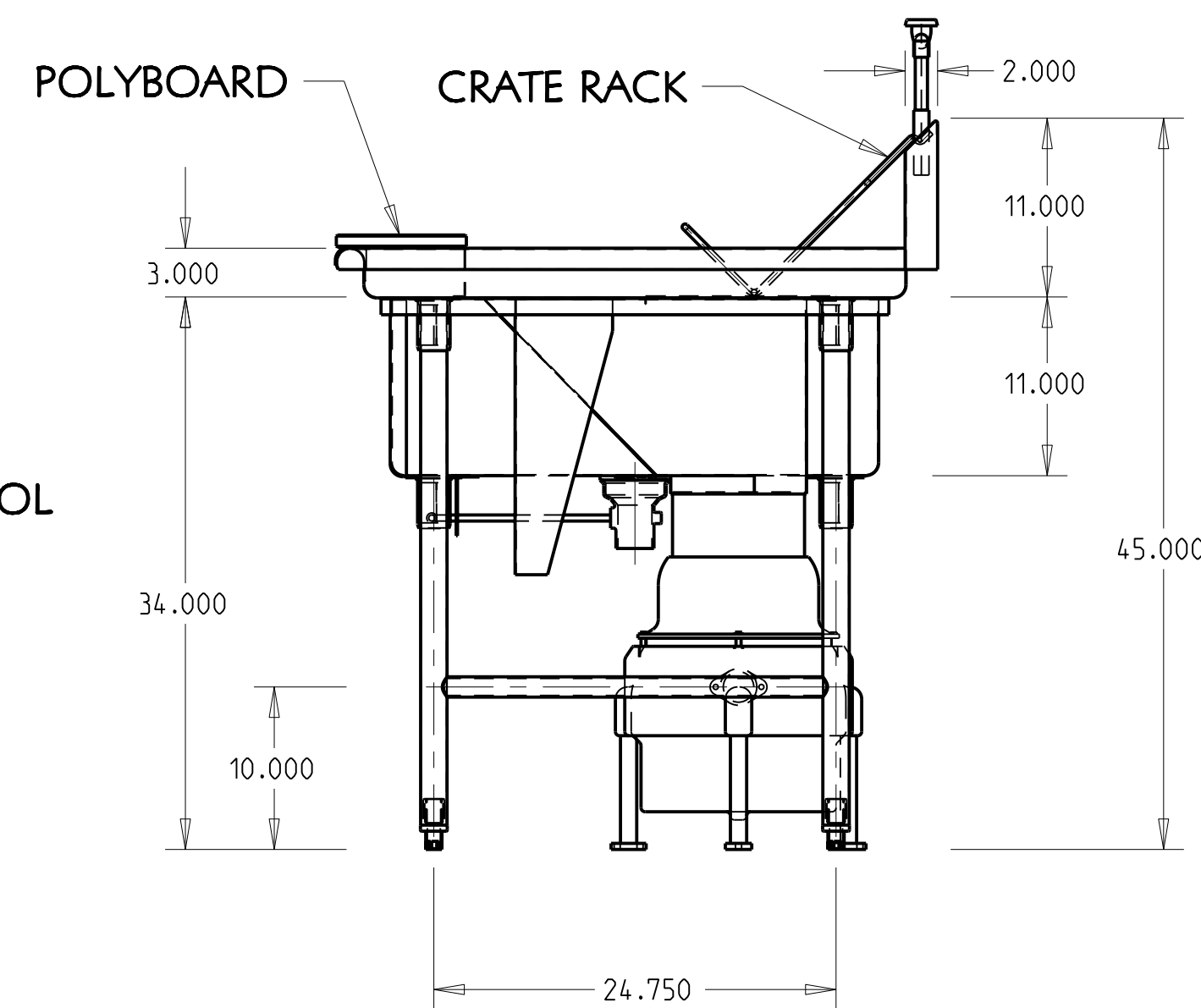
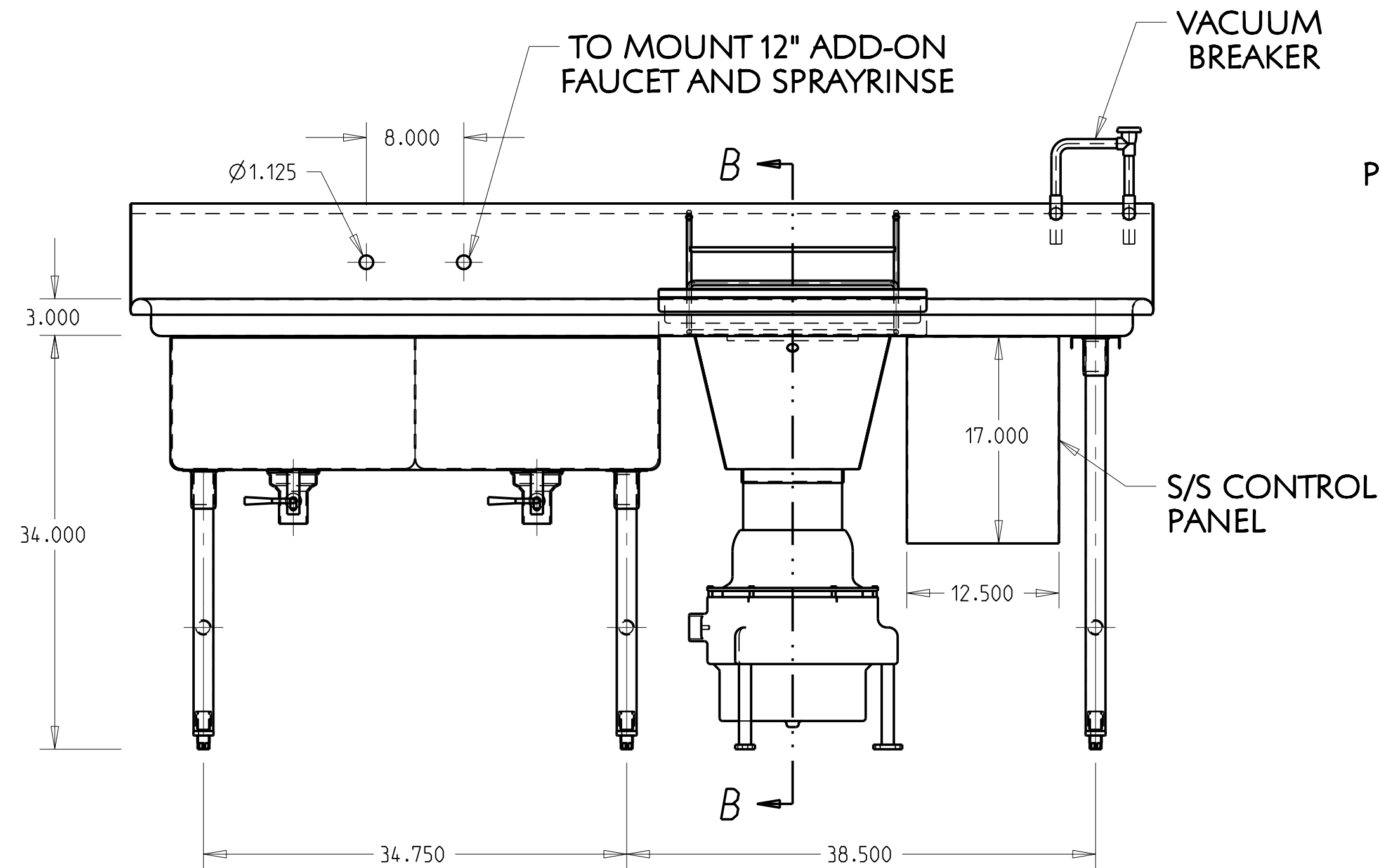

NO.	DATE	REVISIONS	BY
ASSEM		PPS-84-2T	

