

PURCHASED ITEMS

KEY	DESCRIPTION	QTY.	U/M	INV. CODE	VENDOR NAME	PART/MODEL NUMBER	PART TYPE
1	DUO BASKET DRAIN, E38-1010	1	EA	BO	COMPONENT	E38-1010	ASSEMBLY

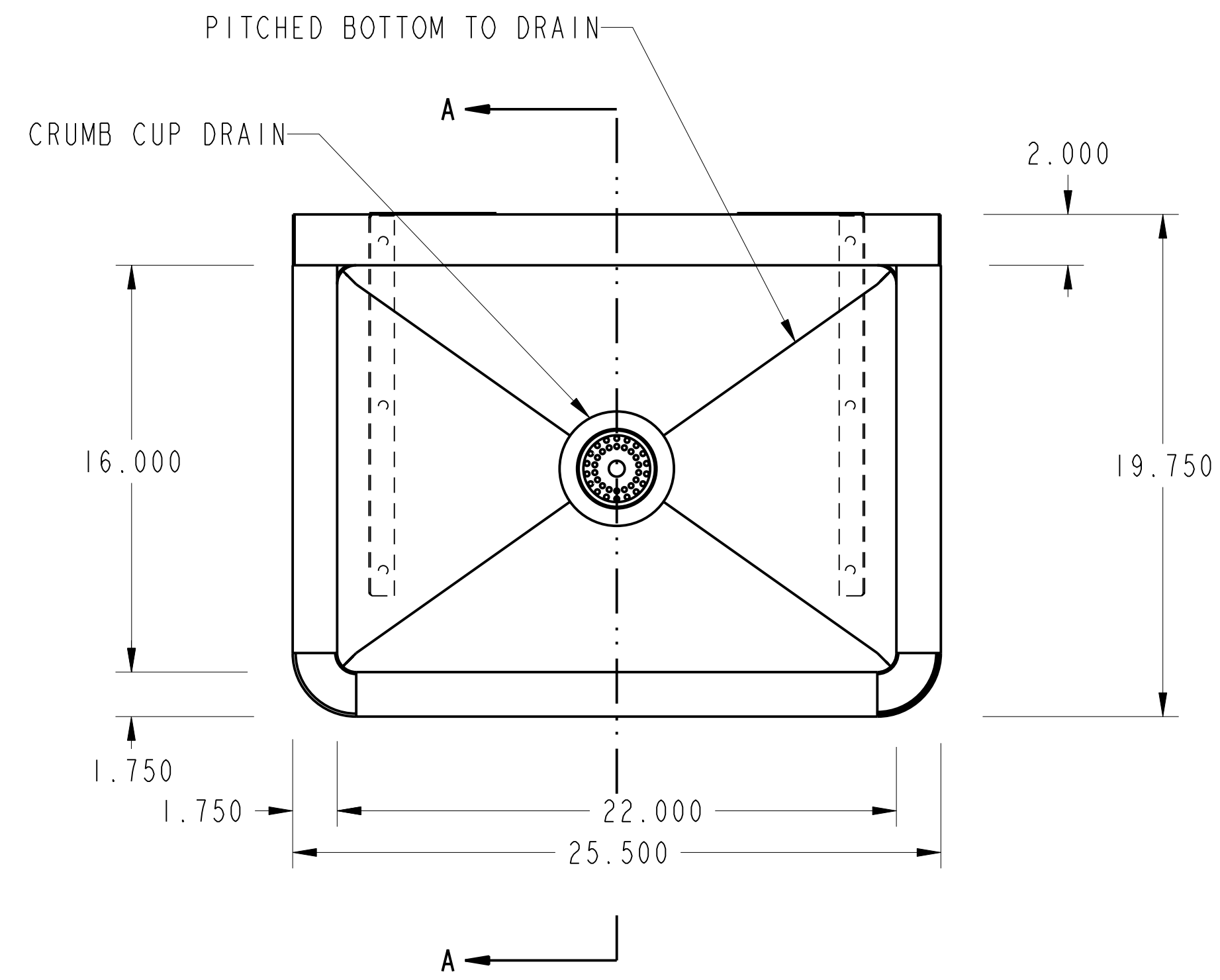

TOP: 14 GA S/S ALL WELDED CONSTRUCTION W/ INTEGRAL 10" HIGH BACKSPLASH ALL HORIZONTAL AND VERTICAL CORNERS TO BE COVERED TO 3/4" RAD. WITH INTEGRAL SINK

BRACKET : 16 GA S/S WELDED TO THE TOP

NOTES: ALL S/S TO BE TYPE 300 SERIES.
ALL S/S TO BE POLISHED TO NO. 3 FINISH
ALL UNEXPOSED WELDS TO BE COVERED W/ ALUMINUM PAINT.
ALL METAL EDGES TO BE FILED SMOOTH.

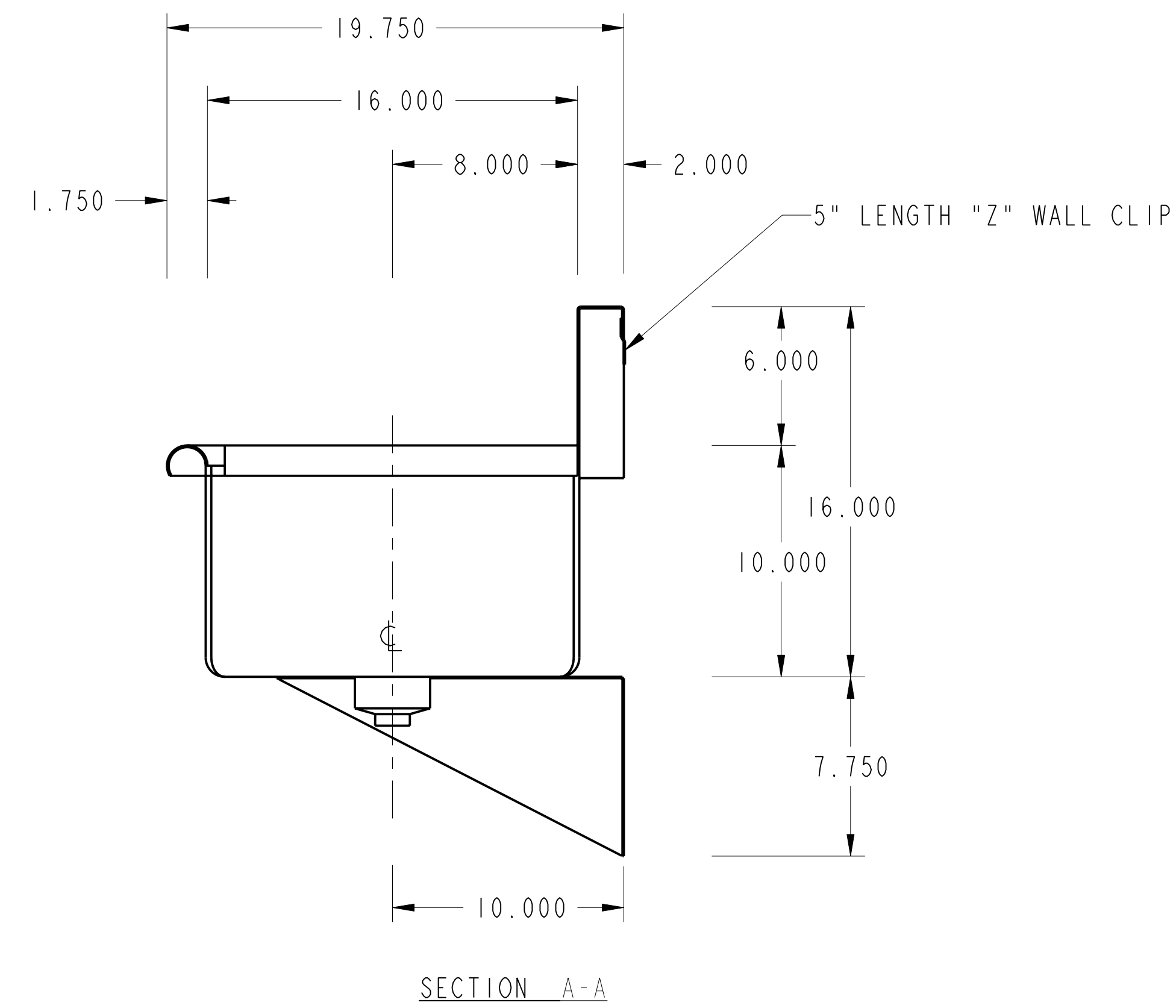
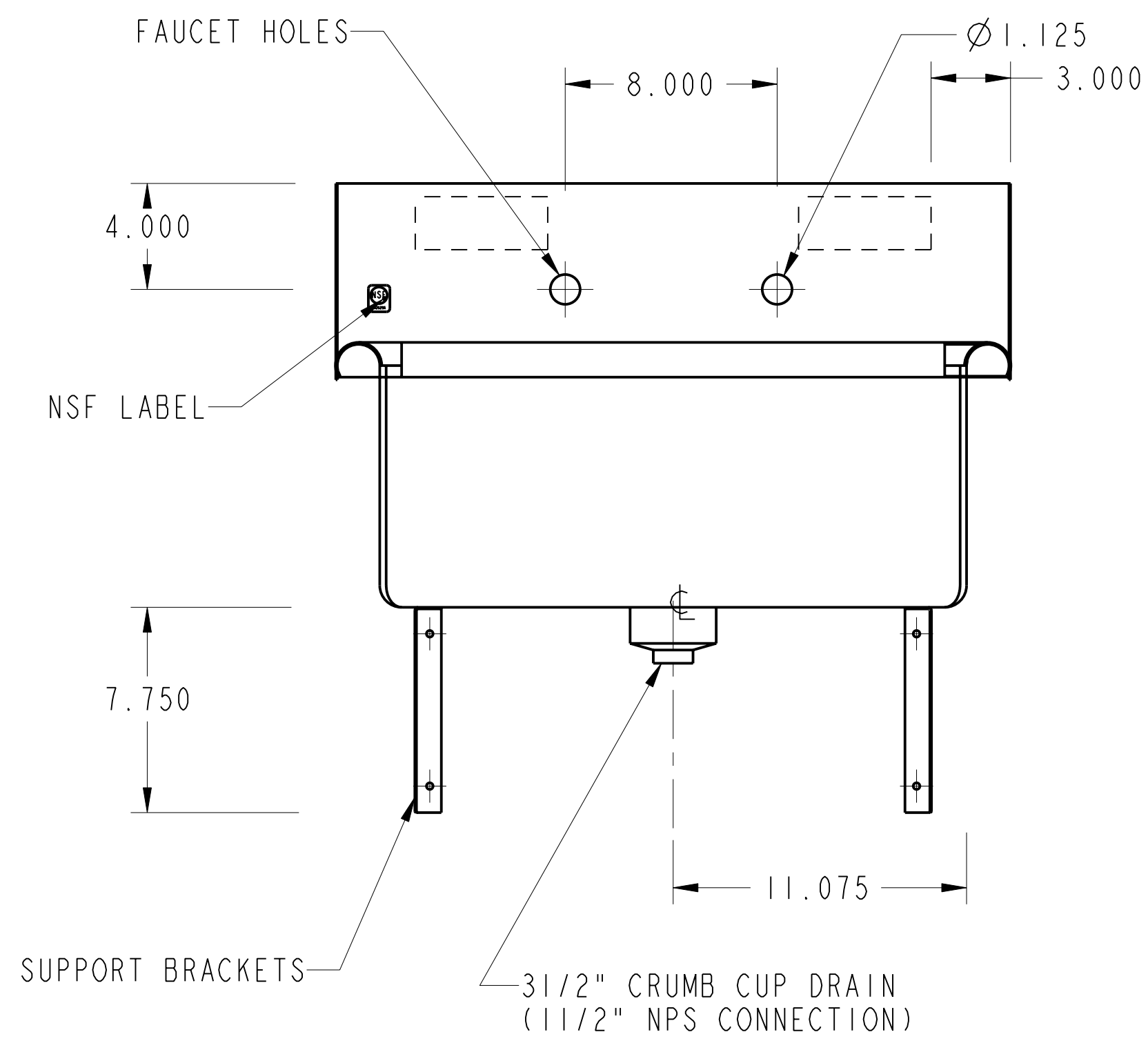
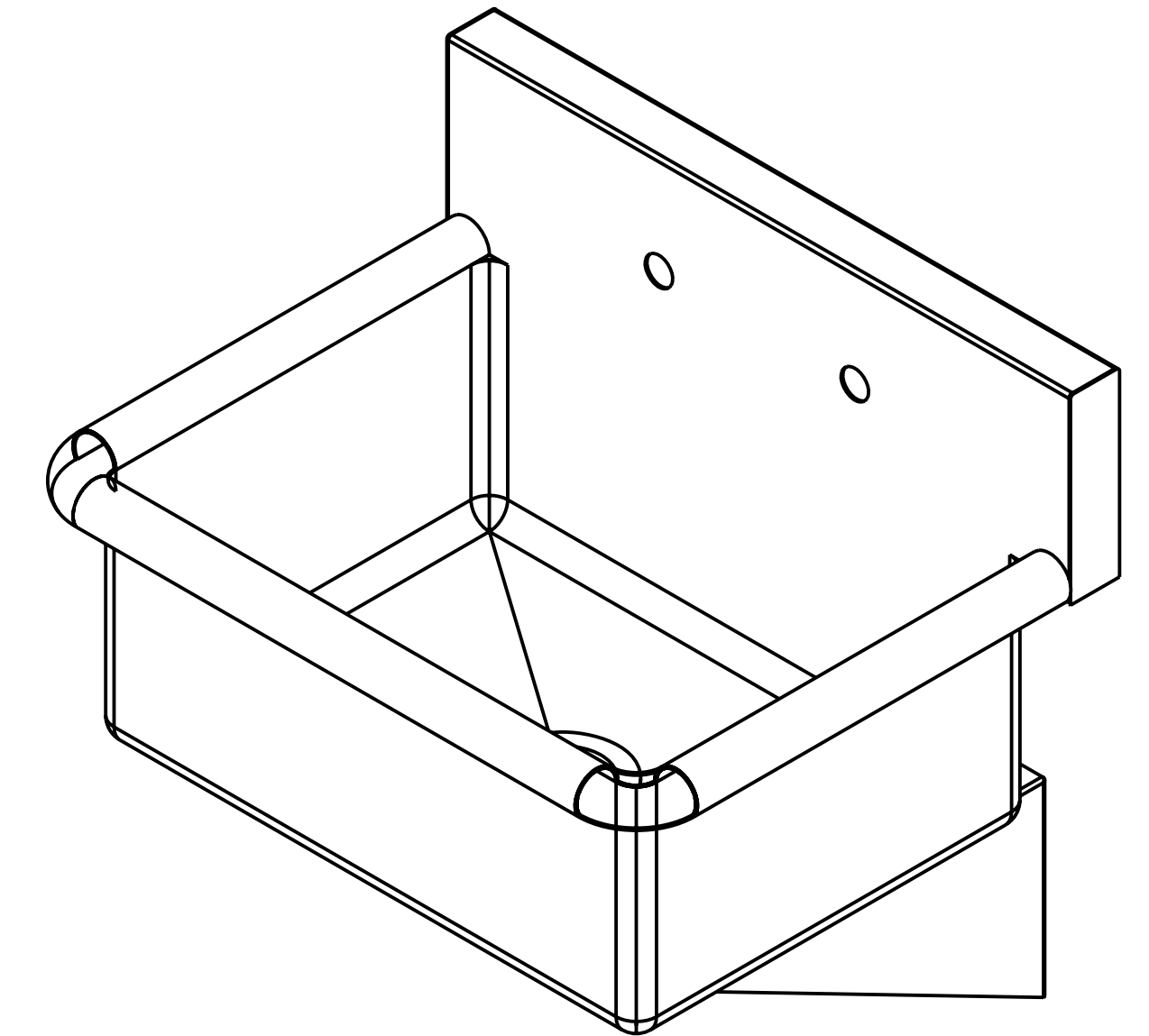

NO.	DATE	REVISIONS	BY
ASSEM		SCS-2216	



PRO