

URINAL: 16 GA. STN/STL ALL WELDED CONSTRUCTION WITH INTEGRAL DEPRESSED DRAIN AS SHOWN.
 BRACKET: 14 GA. STN/STL ALL WELDED CONSTRUCTION, STUD WELDED TO BOTTOM SURFACE.
 NOTES: ALL STN STL TO BE TYPE 304.
 ALL STN STL TO BE POLISHED TO NO. 3 FINISH.
 ALL UNEXPOSED WELDS TO BE COATED WITH ALUMINUM PAINT.
 ALL METAL EDGES TO BE FILED SMOOTH. NO SHARP EDGES OR CORNERS.

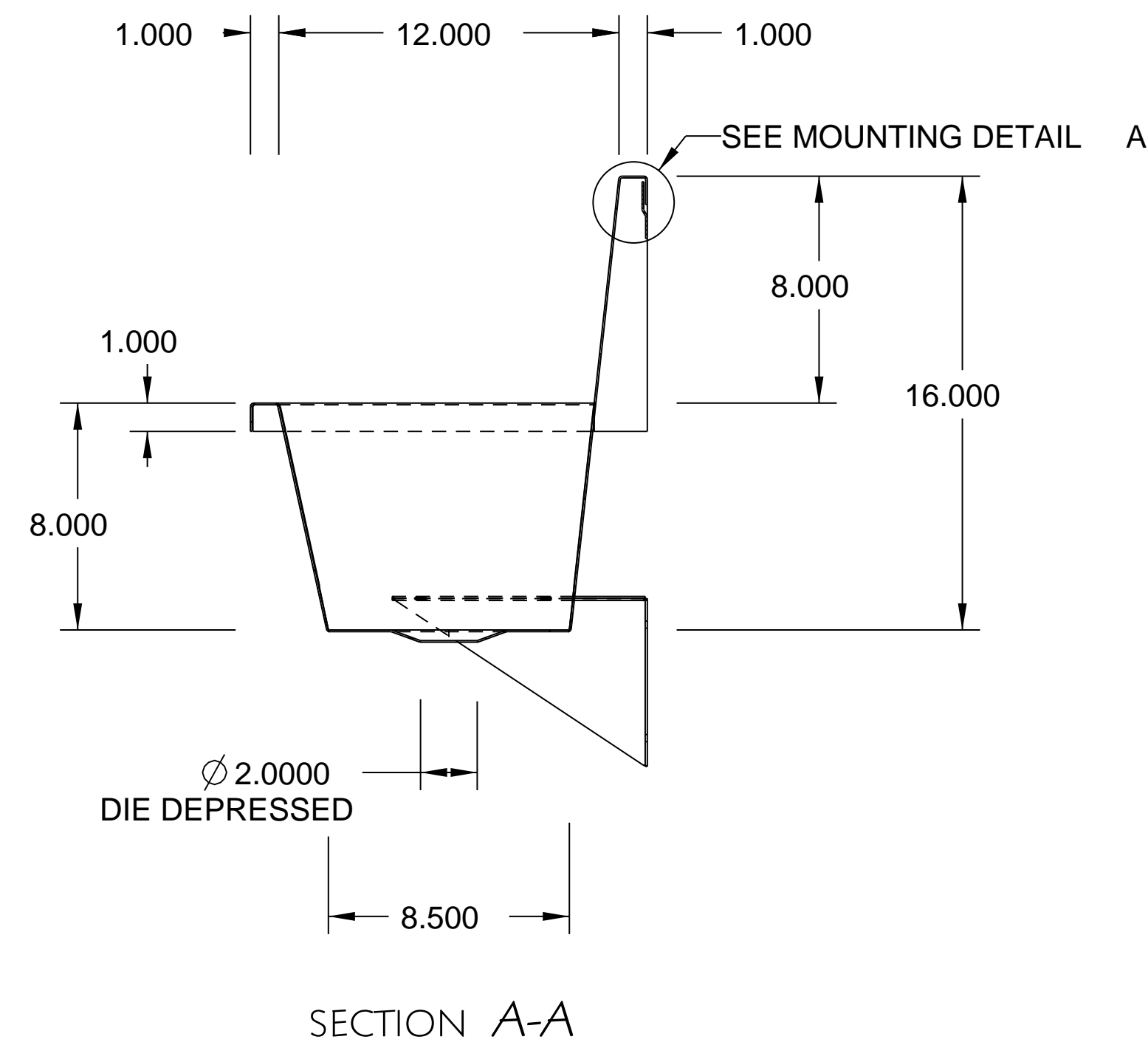

NO.	DATE	REVISIONS	BY
ASSEM		SSU-48	

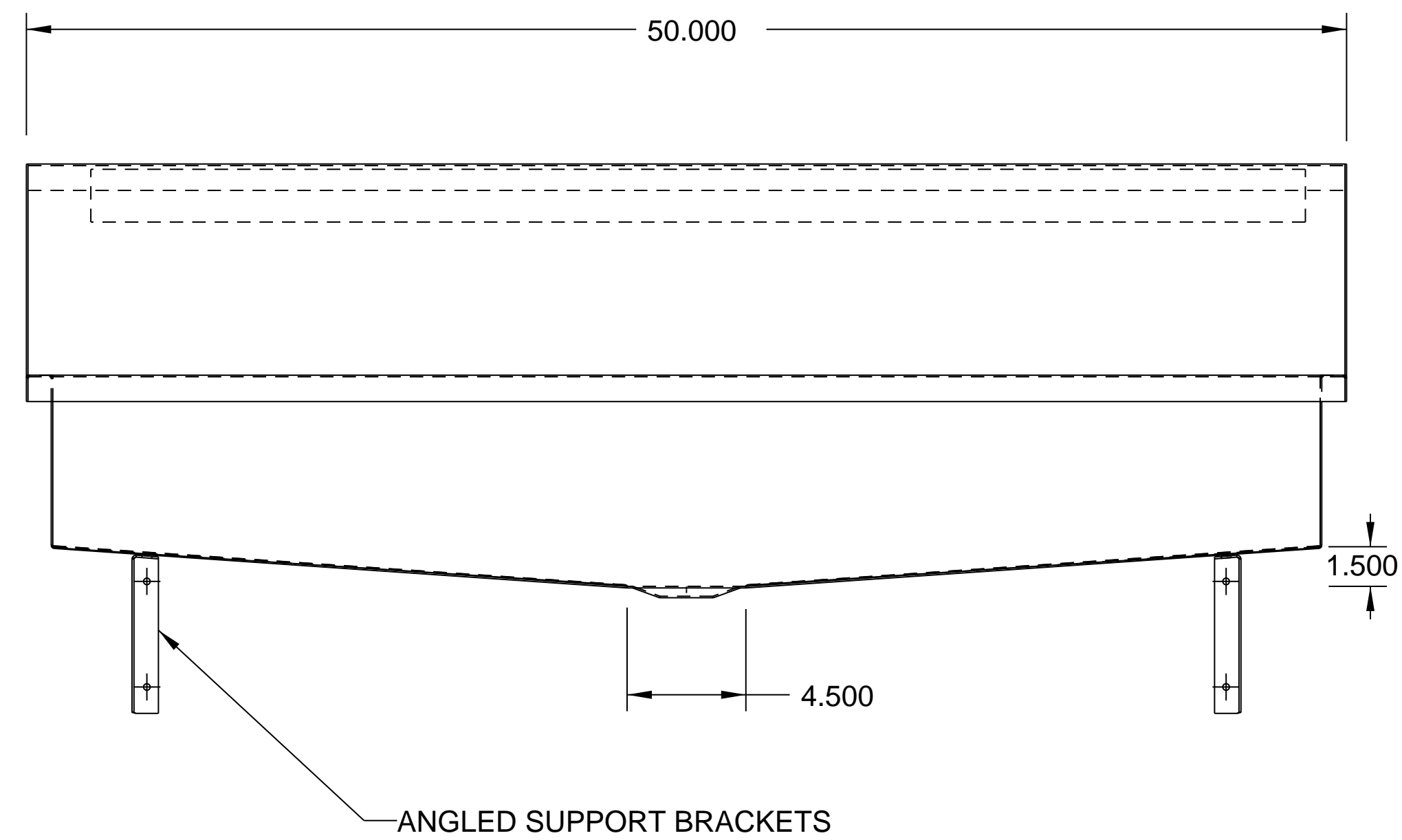
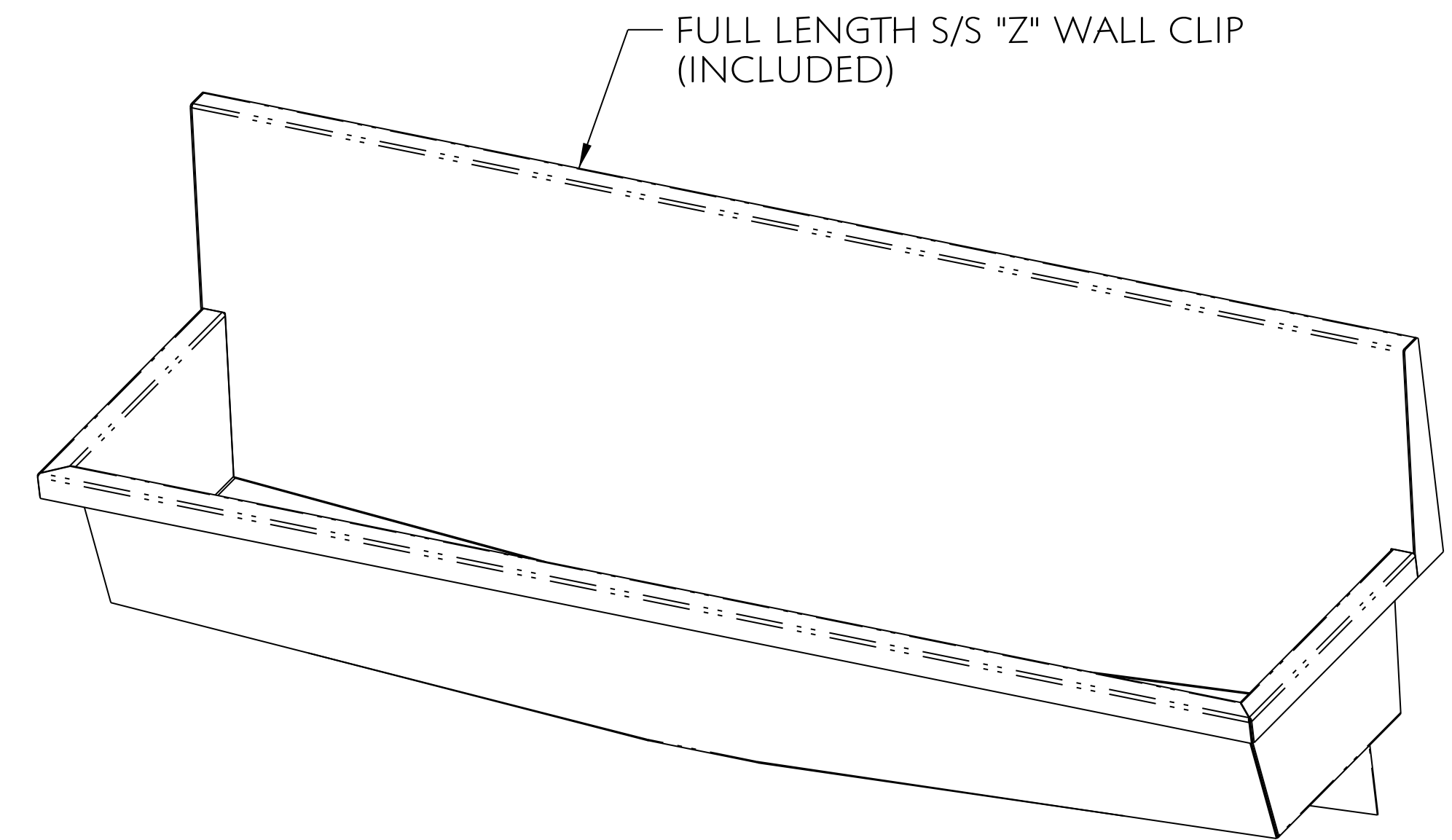
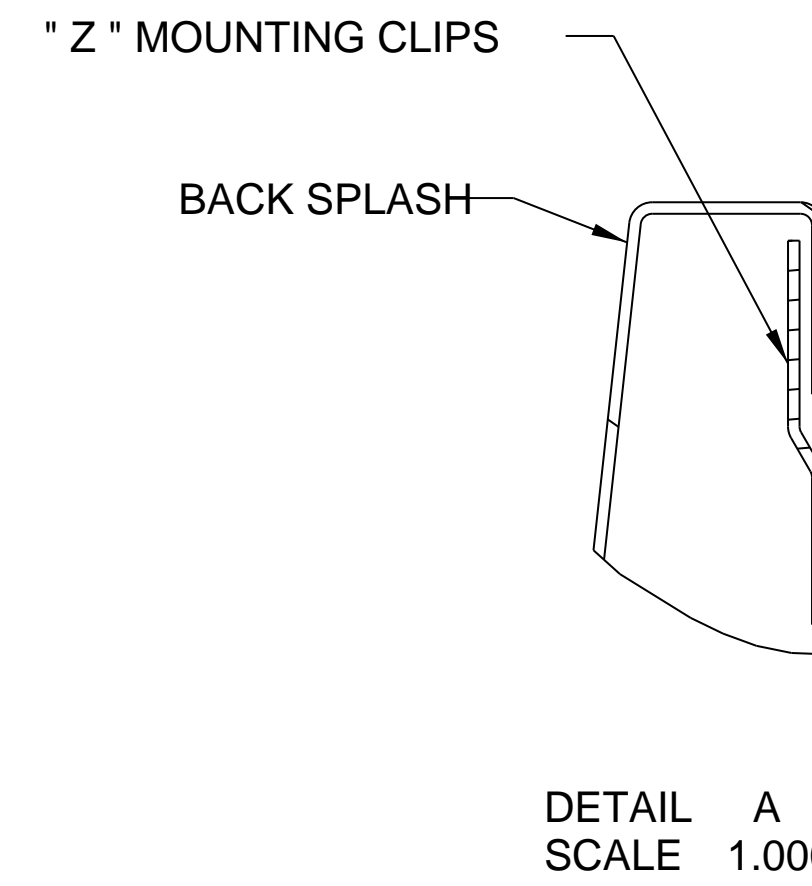
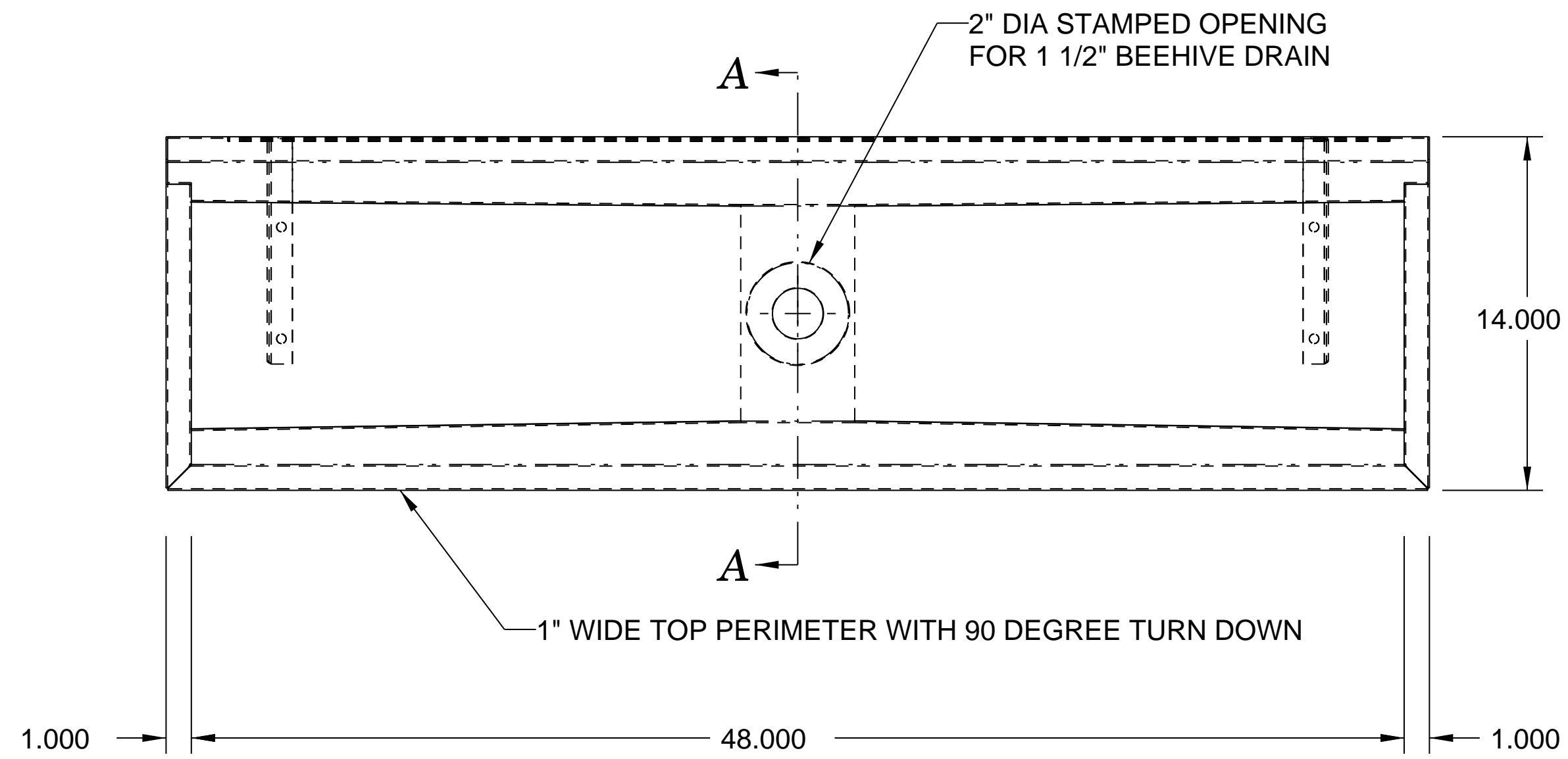

PRO

AMTEKCO INDUSTRIES, INC.

MANUFACTURERS OF QUALITY PRODUCTS FOR
 THE FOOD MARKETING INDUSTRY
 1205 REFUGEE RD. COLUMBUS, OHIO 43207
 (614)228-6590 Fax (614)443-4807

AMTEKCO
 SSU-48 S/S URINAL

APPROVED BY	CHKD BY	DATE	SCALE	
		14-Jun-07	0200	
DATE	CODE	DRAWING No.	REV.	PARTSHEET

SSU-48

THIS DRAWING IS THE PROPERTY OF AMTEKCO INDUSTRIES INC. AND IS TO REMAIN IN THE POSSESSION OF OUR REPRESENTATIVE UNLESS PERMISSION IS GIVEN BY AMTEKCO INDUSTRIES INC. AND MUST BE RETURNED WHEN REQUESTED.