

PURCHASED ITEMS

KEY	DESCRIPTION	QTY.	U/M	INV. CODE	VENDOR NAME	PART/MODEL NUMBER	PART TYPE

DRP IN: 16 GA. STN/STL ALL WELDED CONSTRUCTION w/ INTEGRAL SINK. ALL HORIZONTAL AND VERTICAL CORNERS TO BE A 3/4" RADIUS.

NOTES:
 ALL STN/STL TO BE TYPE 300 SERIES.
 ALL STN/STL TO BE POLISHED TO A NO. 3 FINISH.
 ALL UNEXPOSED WELDS TO BE COVERED w/ ALUMINUM PAINT.
 ALL METAL EDGES AND CORNERS TO BE FILED SMOOTH.

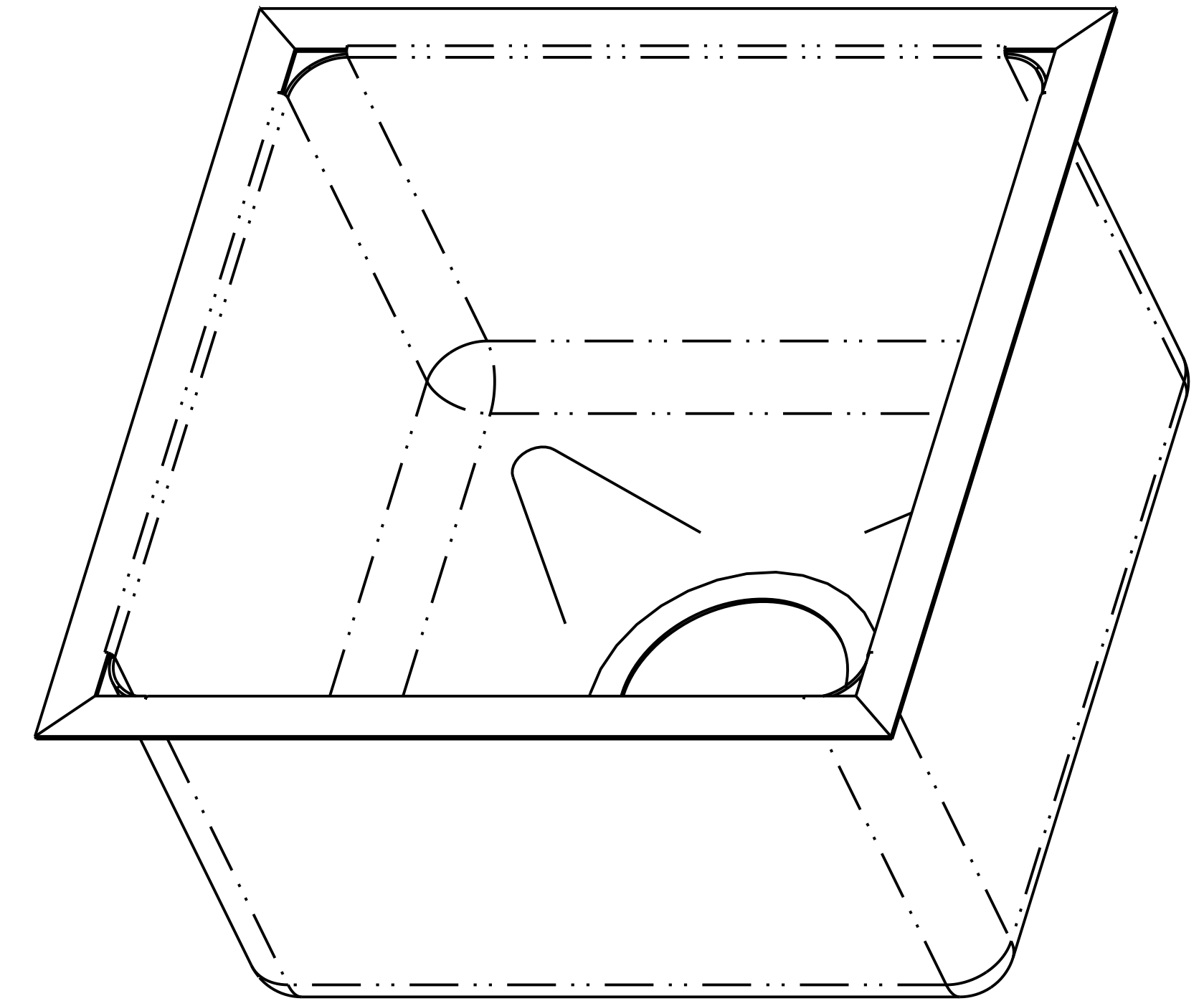
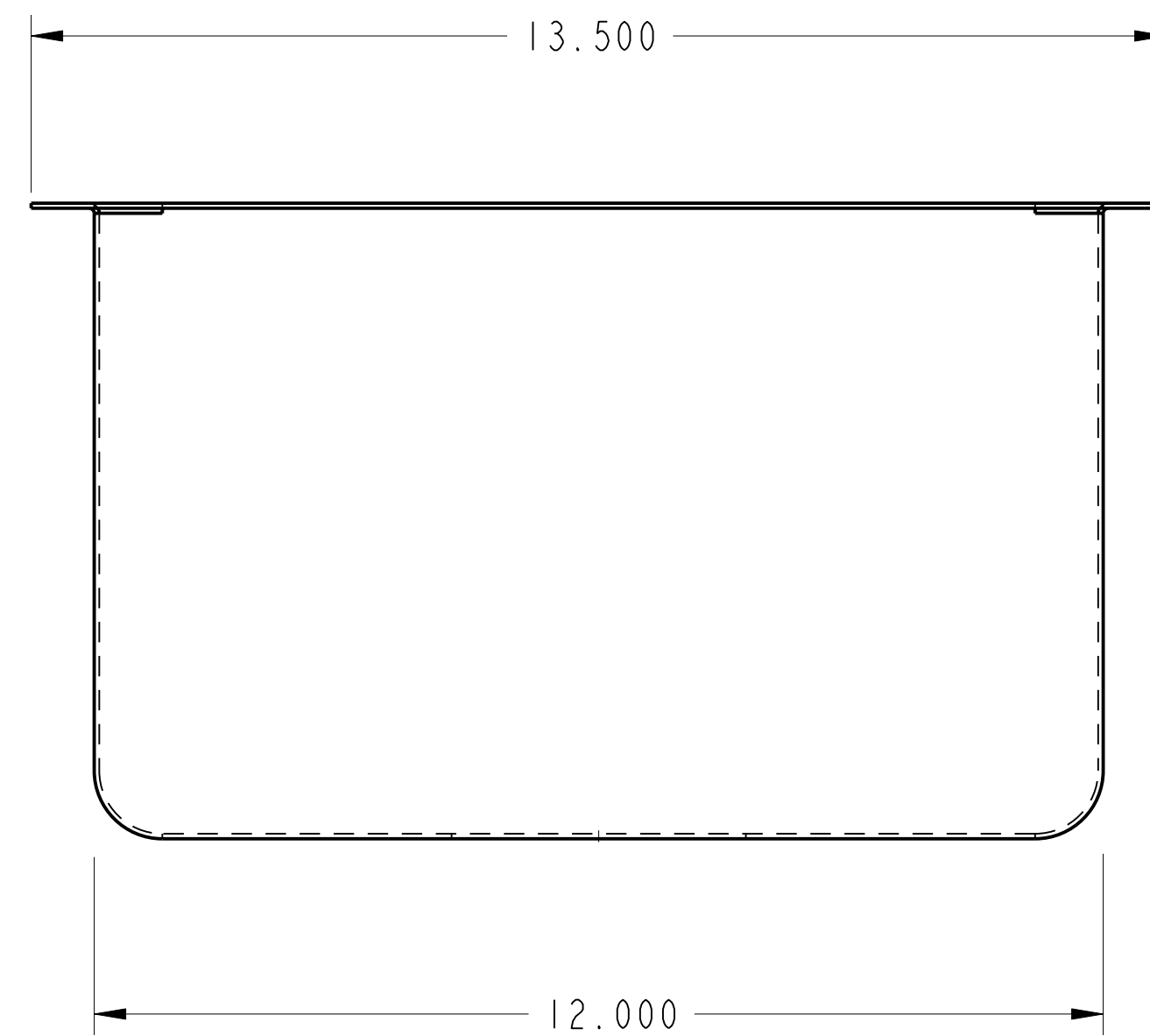
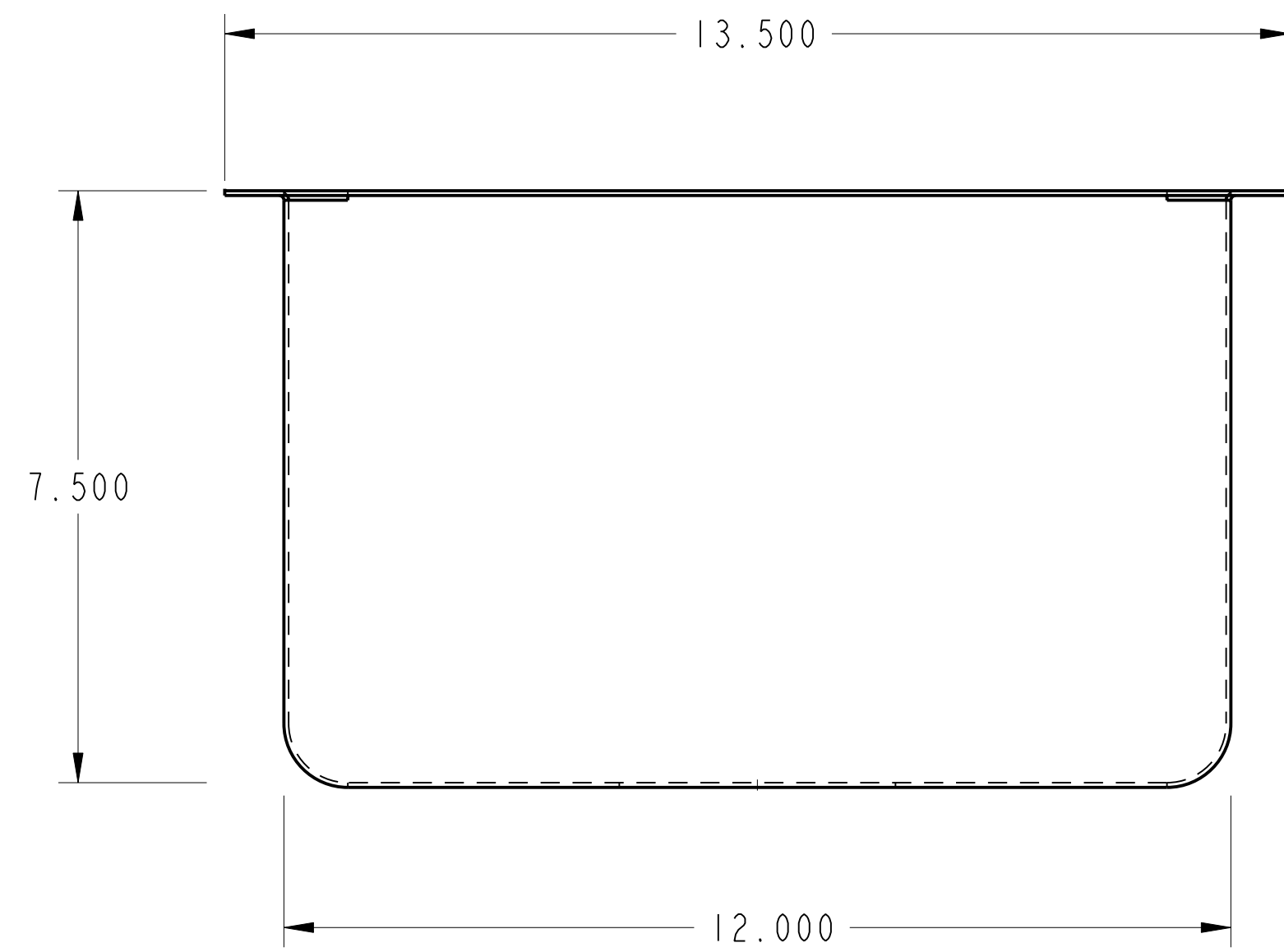
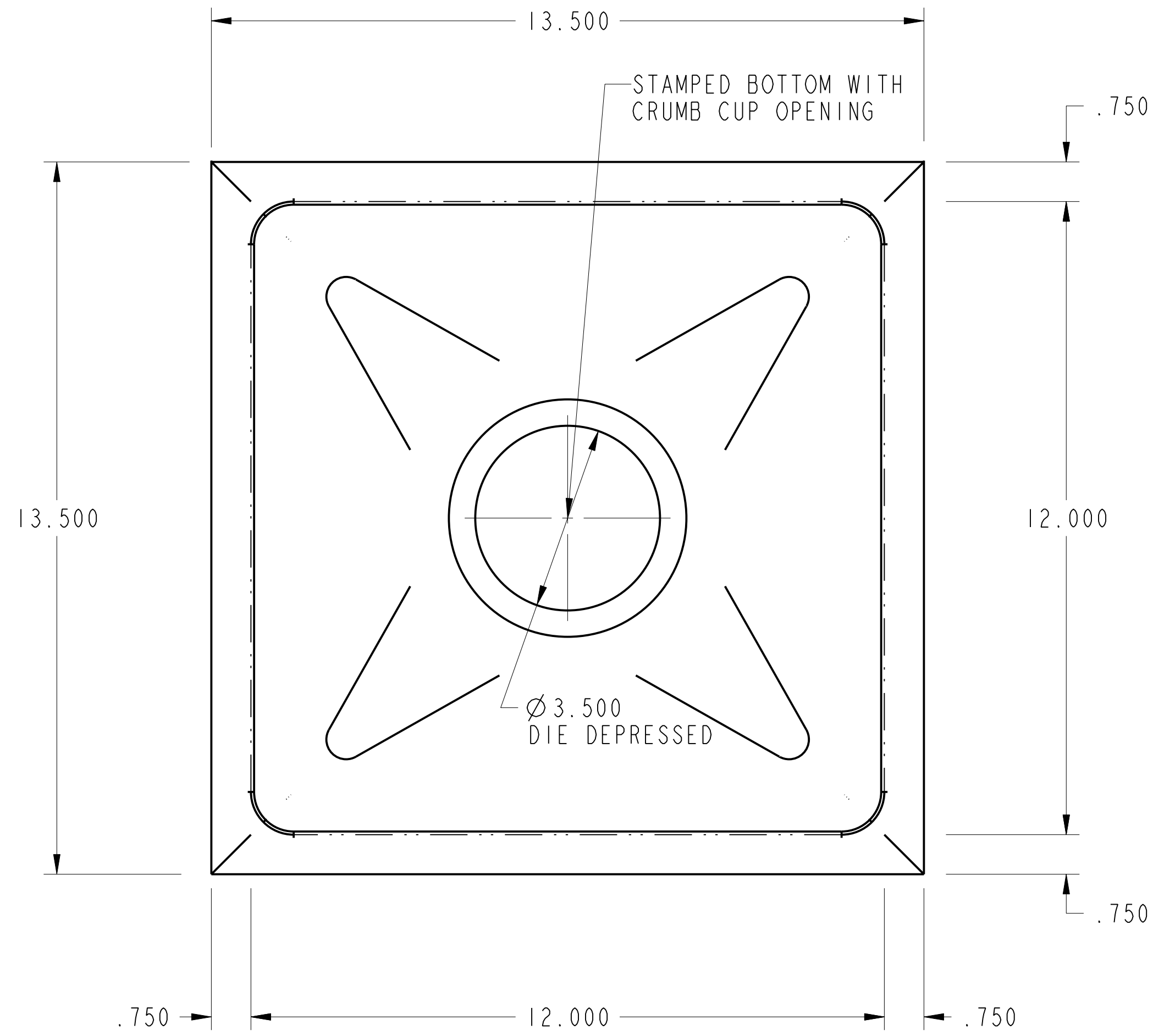

NO.	DATE	REVISIONS	BY

