

PURCHASED ITEMS							
KEY	DESCRIPTION	QTY.	U/M	INV. CODE	VENDOR NAME	PART/MODEL NUMBER	PART TYPE

DRP IN: 16 GA. STN/STL ALL WELDED CONSTRUCTION w/ INTEGRAL SINK. ALL HORIZONTAL AND VERTICAL CORNERS TO BE A 3/4" RADIUS.

NOTES: ALL STN/STL TO BE TYPE 300 SERIES.  
 ALL STN/STL TO BE POLISHED TO A NO. 3 FINISH.  
 ALL UNEXPOSED WELDS TO BE COVERED w/ ALUMINUM PAINT.  
 ALL METAL EDGES AND CORNERS TO BE FILED SMOOTH.

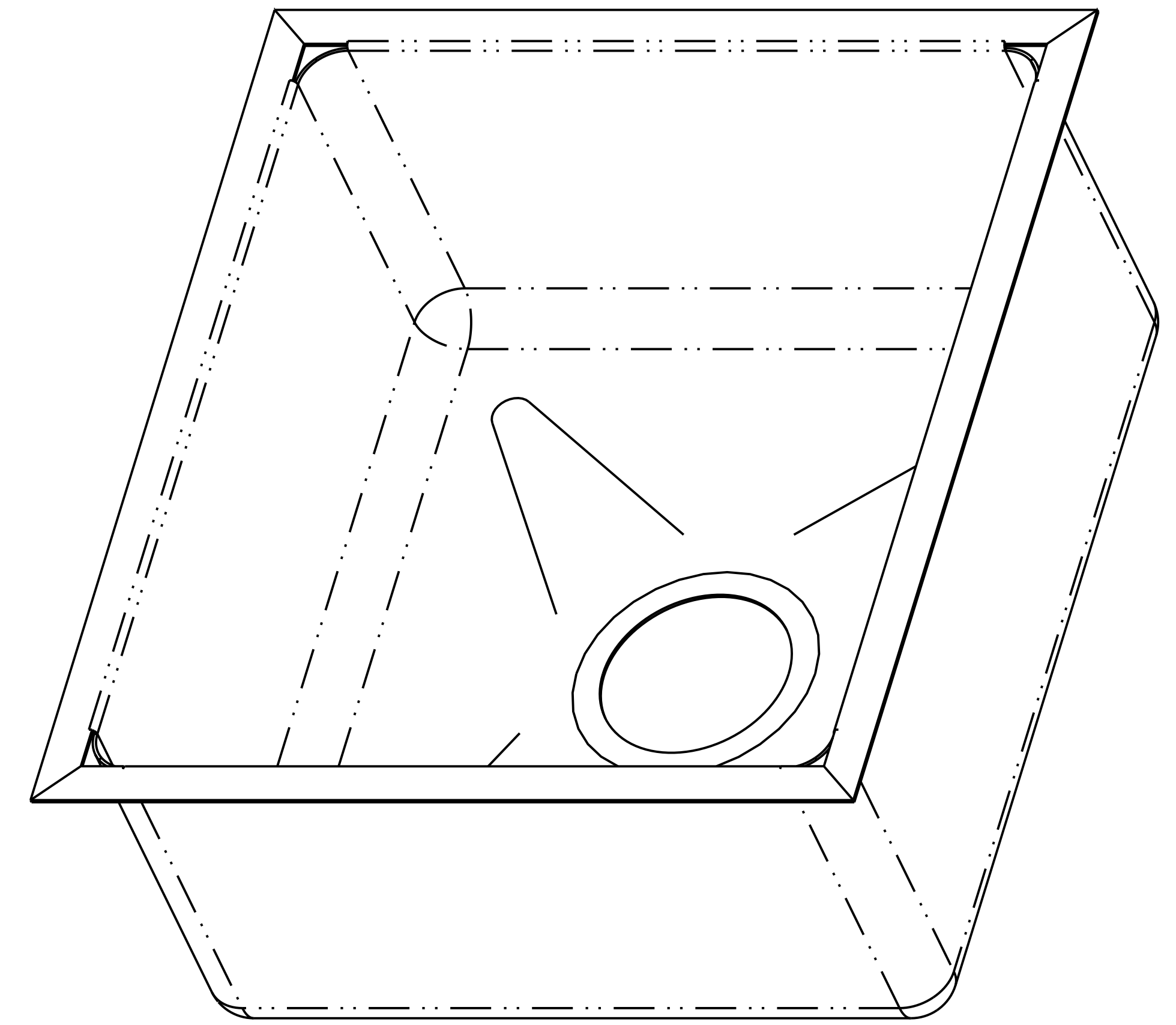

NO.	DATE	REVISIONS	BY
ASSEM		UM-1-1416-7_5	



**AMTEKCO INDUSTRIES, INC.**  
 MANUFACTURERS OF QUALITY PRODUCTS FOR THE FOOD MARKETING INDUSTRY  
 1205 REFUGEE ROAD COLUMBUS, OHIO 43207  
 (614)228-6590 Fax (614)737-8016

**AMTEKCO INDUSTRIES**  
 UNDERMOUNT SINK (UM-1-1416-7.5)

APPROVED BY	CKD BY	DATE	SCALE
		26-Sep-06	0500
DATE	CODE	DRAWING No.	REV. PART/SHEET
		UM-1-1416-7.5	1 of 1

THIS DRAWING IS THE PROPERTY OF AMTEKCO INDUSTRIES, INC., AND IS TO REMAIN IN THE POSSESSION OF OUR REPRESENTATIVE UNLESS PERMISSION IS GIVEN BY AMTEKCO INDUSTRIES, INC., AND MUST BE RETURNED WHEN REQUESTED.