

PURCHASED ITEMS

KEY	DESCRIPTION	QTY.	U/M	INV. CODE	VENDOR NAME	PART/MODEL NUMBER	PART TYPE

DROP IN TOP : 16 GA. STN/STL ALL WELDED CONSTRUCTION.
 SINK : 16 GA. STN/STL ALL WELDED CONSTRUCTION.
 ALL HORIZONTAL AND VERTICAL CORNERS TO BE A 3/4" RADIUS.

NOTES: ALL STN/STL TO BE TYPE 300 SERIES.
 ALL STN/STL TO BE POLISHED TO A NO. 3 FINISH.
 ALL UNEXPOSED WELDS TO BE COVERED w/ ALUMINUM PAINT.
 ALL METAL EDGES AND CORNERS TO BE FILED SMOOTH.

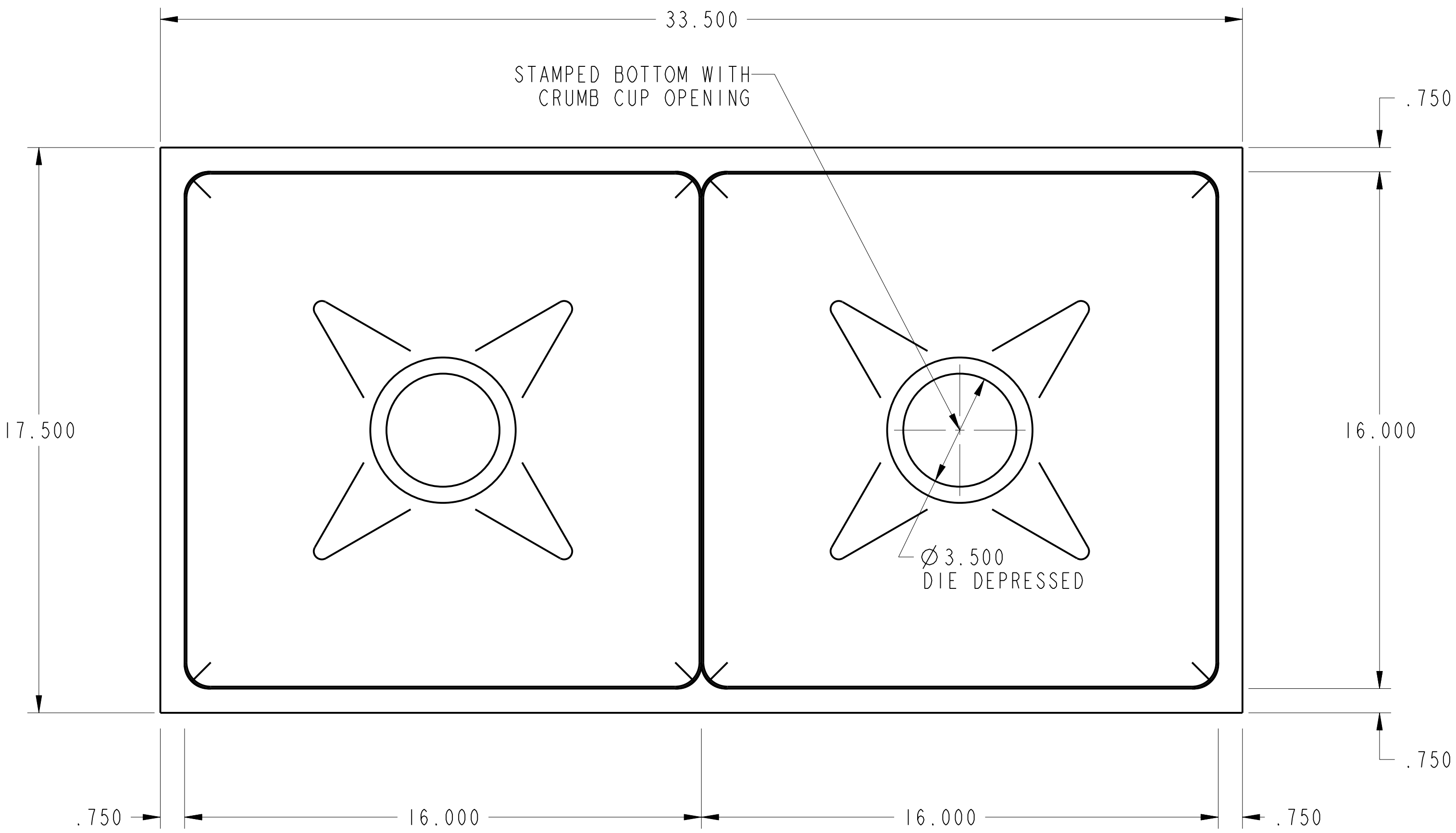

PLAN VIEW

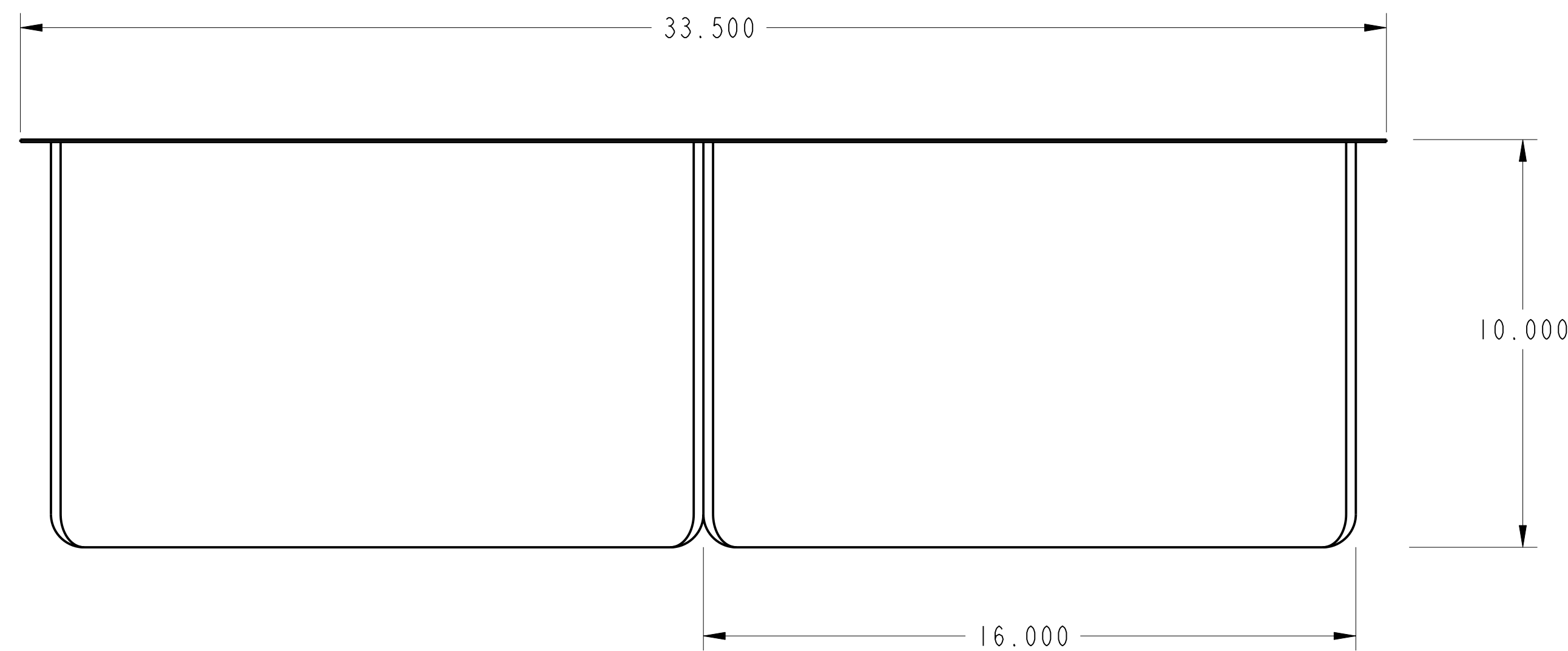
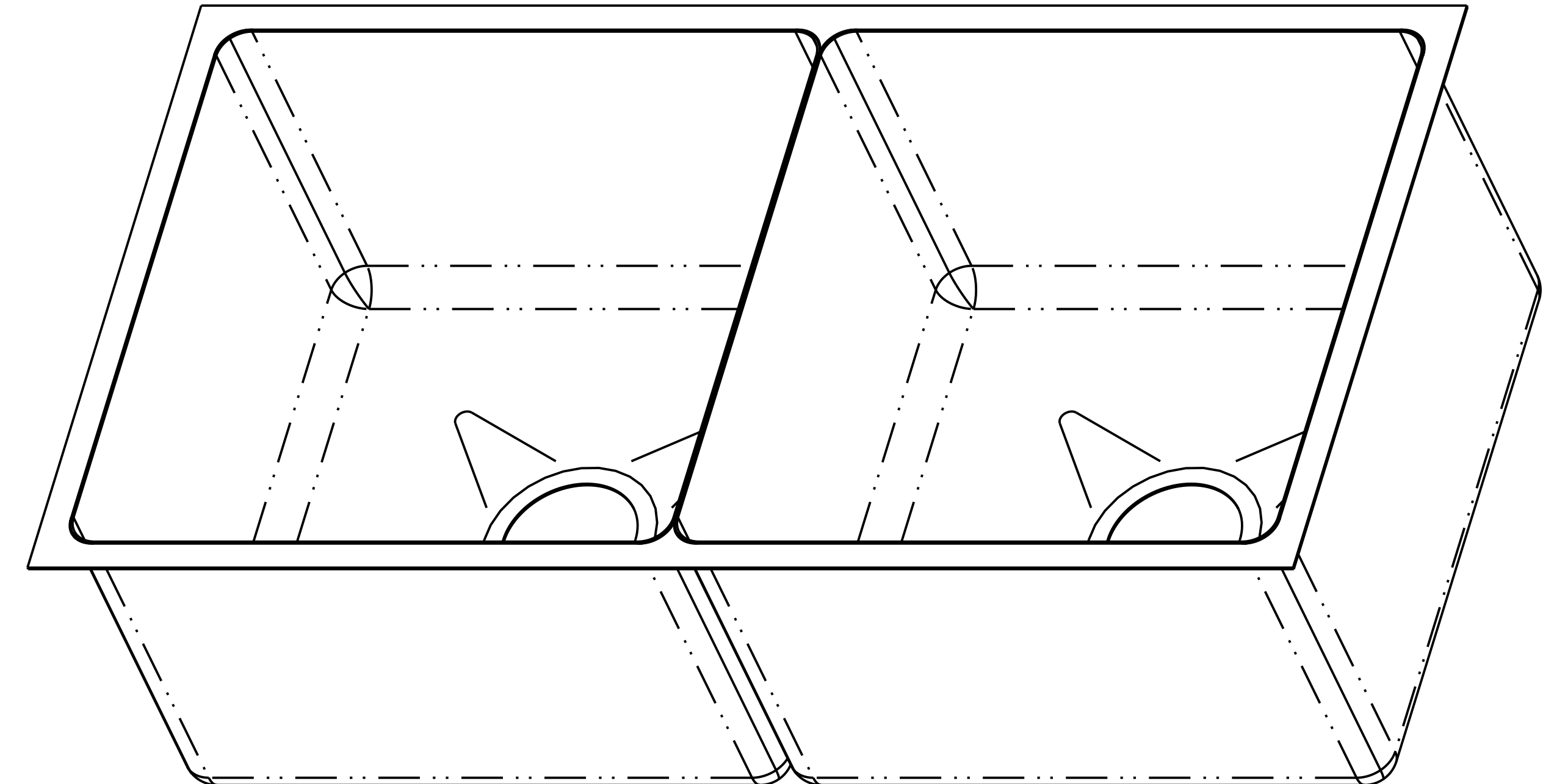

FRONT ELEVATION

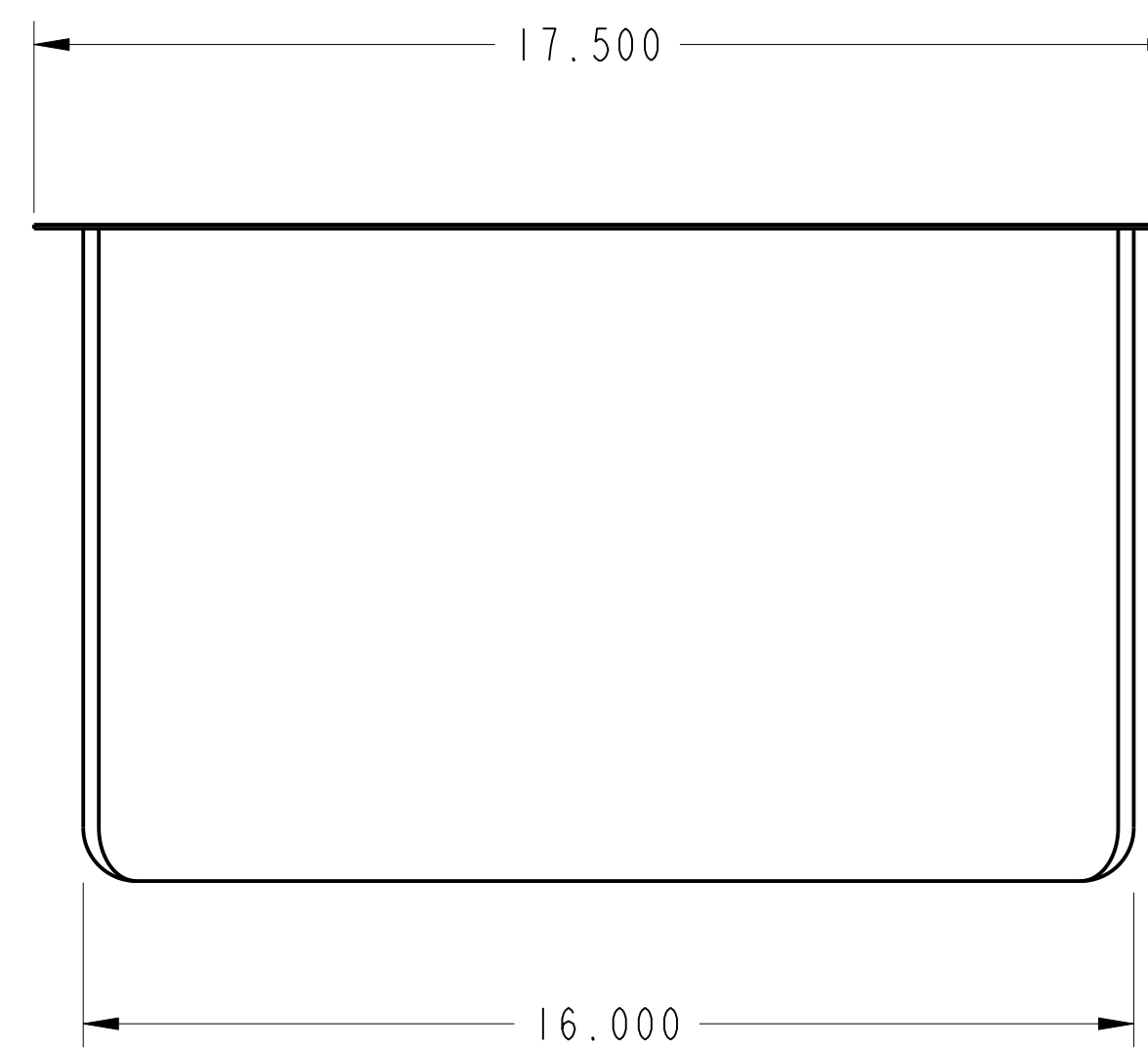

NO.	DATE	REVISIONS	BY

ASSEM	UM-2-1616-10		
-------	--------------	--	--



PRO

THIS DRAWING IS THE PROPERTY OF AMTEKCO INDUSTRIES, INC., AND IS TO REMAIN IN THE POSSESSION OF OUR REPRESENTATIVE UNLESS PERMISSION IS GIVEN BY AMTEKCO INDUSTRIES, INC., AND MUST BE RETURNED WHEN REQUESTED.