



THREE COMPARTMENT DROP-IN SINK WITH NO DRAINBOARDS

PROJECT#: _____

ITEM# _____

MODEL# _____

Model #	Bowl Size L x W x D	O.A. Dims L x W	Model #	Bowl Size L x W x D	O.A. Dims L x W
D-3-1212-4.5	12" x 12" x 4 1/2"	39" x 17 1/2"	D-3-1416-4.5	14" x 16" x 4 1/2"	45" x 21 1/2"
D-3-1212-7.5	12" x 12" x 7 1/2"	39" x 17 1/2"	D-3-1416-7.5	14" x 16" x 7 1/2"	45" x 21 1/2"
D-3-1212-10	12" x 12" x 10"	39" x 17 1/2"	D-3-1416-10	14" x 16" x 10"	45" x 21 1/2"
D-3-1216-4.5	12" x 16" x 4 1/2"	39" x 21 1/2"	D-3-1916-4.5	19" x 16" x 4-1/2"	60" x 21 1/2"
D-3-1216-7.5	12" x 16" x 7 1/2"	39" x 21 1/2"	D-3-1916-7.5	19" x 16" x 7 1/2"	60" x 21 1/2"
D-3-1216-10	12" x 16" x 10"	39" x 21 1/2"	D-3-1916-10	19" x 16" x 10"	60" x 21 1/2"

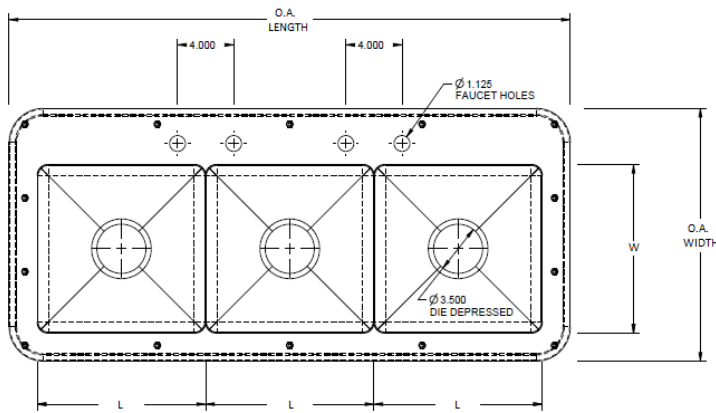

PLAN

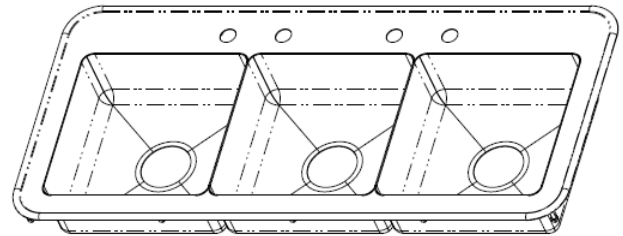

ISOMETRIC VIEW

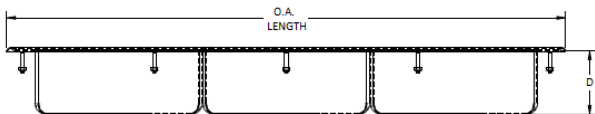

ELEVATION

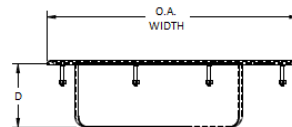

SECTION

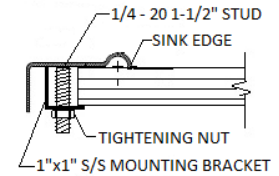

DETAIL SECTION

Mechanical Specifications

- 16 gauge 304 stainless steel fabrication
- 3 1/2" drain opening with crumb cup drain and basket strainers 1 1/2" IPS
 - Fully welded, seamless and polished to a #3 commercial finish
 - Horizontal and vertical corners covered to a 3/4" radius
 - Die formed depression to drain in bowl bottom
 - 1 set of faucet holes 4" o.c.
 - 1" x 1" stainless steel mounting bracket
 - 1/4 - 20 studs @ 1 1/2" long welded to underside of sink edge
 - Feathered edge around perimeter of sink bowl on all 4 sides
 - NSF listed and labeled

Optional

- 14 gauge 304 stainless steel fabrication available
 - Different bowl sizes and depths
 - Additional faucet drillings
 - Sound deadening to underside of sink bowl
 - ADA options



THREE COMPARTMENT DROP-IN SINK WITH TWO DRAINBOARDS

PROJECT#: _____

ITEM# _____

MODEL# _____

Model #	Bowl Size L x W x D	O.A. Dims L x W	Model #	Bowl Size L x W x D	O.A. Dims L x W
DWDD-3-1416-4.5-15.5 D	14" x 16" x 4 1/2"	73" x 21 1/2"	DWDD-3-1616-4.5-15.5 D	16" x 16" x 4 1/2"	79" x 21 1/2"
DWDD-3-1416-7.5-15.5 D	14" x 16" x 7 1/2"	73" x 21 1/2"	DWDD-3-1616-7.5-15.5 D	16" x 16" x 7 1/2"	79" x 21 1/2"
DWDD-3-1416-10-15.5 D	14" x 16" x 10"	73" x 21 1/2"	DWDD-3-1616-10-15.5 D	16" x 16" x 10"	79" x 21 1/2"
DWDD-3-1416-4.5-18.5 D	14" x 16" x 4 1/2"	79" x 21 1/2"	DWDD-3-1616-4.5-18.5 D	16" x 16" x 4 1/2"	85" x 21 1/2"
DWDD-3-1416-7.5-18.5 D	14" x 16" x 7 1/2"	79" x 21 1/2"	DWDD-3-1616-7.5-18.5 D	16" x 16" x 7 1/2"	85" x 21 1/2"
DWDD-3-1416-10-18.5 D	14" x 16" x 10"	79" x 21 1/2"	DWDD-3-1616-10-18.5 D	16" x 16" x 10"	85" x 21 1/2"
DWDD-3-1416-4.5-24.5 D	14" x 16" x 4 1/2"	91" x 21 1/2"	DWDD-3-1616-4.5-24.5 D	16" x 16" x 4 1/2"	97" x 21 1/2"
DWDD-3-1416-7.5-24.5 D	14" x 16" x 7 1/2"	91" x 21 1/2"	DWDD-3-1616-7.5-24.5 D	16" x 16" x 7 1/2"	97" x 21 1/2"
DWDD-3-1416-10-24.5 D	14" x 16" x 10"	91" x 21 1/2"	DWDD-3-1616-10-24.5 D	16" x 16" x 10"	97" x 21 1/2"

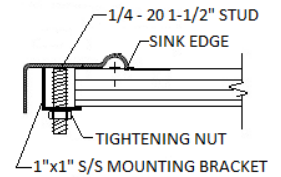
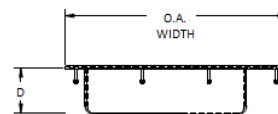
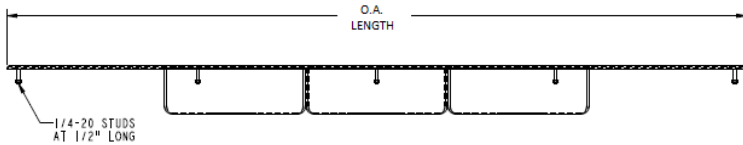
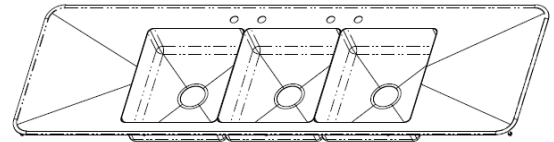
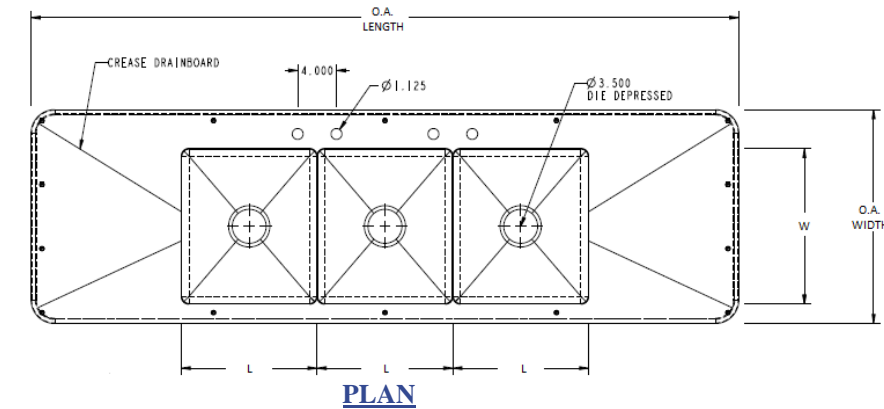

Mechanical Specifications

- 16 gauge 304 stainless steel fabrication
- 3 1/2" drain opening with crumb cup drain and basket strainers 1 1/2" IPS
 - Fully welded, seamless and polished to a #3 commercial finish
 - Horizontal and vertical corners covered to a 3/4" radius
 - Die formed depression to drain in bowl bottom
 - 1 set of faucet holes 4" o.c.
 - 1" x 1" stainless steel mounting bracket
 - 1/4 - 20 studs @ 1 1/2" long welded to underside of sink edge
 - Feathered edge around perimeter of sink bowl on all 4 sides
 - NSF listed and labeled

Optional

- 14 gauge 304 stainless steel fabrication available
 - Different bowl sizes and depths
 - Additional faucet drillings
- Sound deadening to underside of sink bowl
 - ADA options