



**TWO COMPARTMENT DROP-IN SINK WITH NO DRAINBOARDS**

PROJECT#: \_\_\_\_\_

ITEM# \_\_\_\_\_

MODEL# \_\_\_\_\_

Model #	Bowl Size L x W x D	O.A. Dims L x W	Model #	Bowl Size L x W x D	O.A. Dims L x W
<a href="#">D-2-1212-4.5</a>	12" x 12" x 4 1/2"	27" x 17 1/2"	<a href="#">D-2-1416-4.5</a>	14" x 16" x 4 1/2"	31" x 21 1/2"
<a href="#">D-2-1212-7.5</a>	12" x 12" x 7 1/2"	27" x 17 1/2"	<a href="#">D-2-1416-7.5</a>	14" x 16" x 7 1/2"	31" x 21 1/2"
<a href="#">D-2-1212-10</a>	12" x 12" x 10"	27" x 17 1/2"	<a href="#">D-2-1416-10</a>	14" x 16" x 10"	31" x 21 1/2"
<a href="#">D-2-1216-4.5</a>	12" x 16" x 4 1/2"	27" x 21 1/2"	<a href="#">D-2-1916-4.5</a>	19" x 16" x 4 1/2"	41" x 21 1/2"
<a href="#">D-2-1216-7.5</a>	12" x 16" x 7 1/2"	27" x 21 1/2"	<a href="#">D-2-1916-7.5</a>	19" x 16" x 7 1/2"	41" x 21 1/2"
<a href="#">D-2-1216-10</a>	12" x 16" x 10"	27" x 21 1/2"	<a href="#">D-2-1916-10</a>	19" x 16" x 10"	41" x 21 1/2"

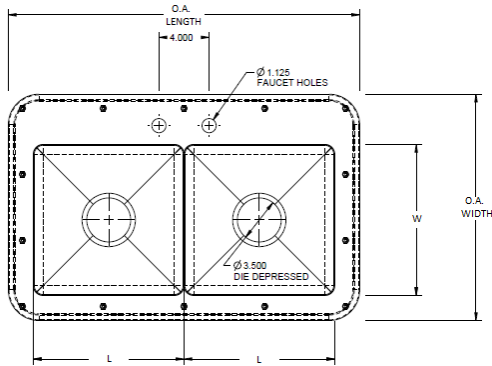

**PLAN**

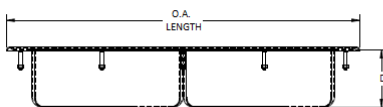

**ELEVATION**

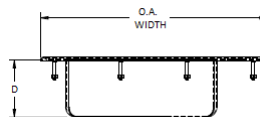

**SECTION**

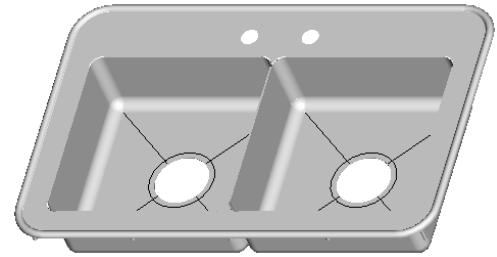

**ISOMETRIC VIEW**

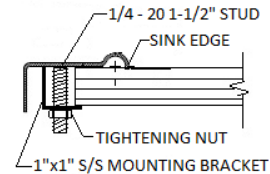

**DETAIL SECTION**

**Mechanical Specifications**

- 16 gauge 304 stainless steel fabrication
- 3 1/2" drain opening with crumb cup drain and basket strainers 1 1/2" IPS
  - Fully welded, seamless and polished to a #3 commercial finish
    - Horizontal and vertical corners covered to a 3/4" radius
    - Die formed depression to drain in bowl bottom
      - 1 set of faucet holes 4" o.c.
      - 1" x 1" stainless steel mounting bracket
  - 1/4 – 20 studs @ 1 1/2" long welded to underside of sink edge
  - Feathered edge around perimeter of sink bowl on all 4 sides
    - NSF listed and labeled

**Optional**

- 14 gauge 304 stainless steel fabrication available
  - Different bowl sizes and depths
    - Additional faucet drillings
  - Sound deadening to underside of sink bowl
    - ADA options



## TWO COMPARTMENT DROP-IN SINK WITH TWO DRAINBOARDS

PROJECT#: \_\_\_\_\_

ITEM# \_\_\_\_\_

MODEL# \_\_\_\_\_

Model #	Bowl Size L x W x D	O.A. Dims L x W	Model #	Bowl Size L x W x D	O.A. Dims L x W
<a href="#">DWDD-2-1416-4.5-15.5 D</a>	14" x 16" x 4 1/2"	59" x 21 1/2"	<a href="#">DWDD-2-1616-4.5-15.5 D</a>	16" x 16" x 4 1/2"	63" x 21 1/2"
<a href="#">DWDD-2-1416-7.5-15.5 D</a>	14" x 16" x 7 1/2"	59" x 21 1/2"	<a href="#">DWDD-2-1616-7.5-15.5 D</a>	16" x 16" x 7 1/2"	63" x 21 1/2"
<a href="#">DWDD-2-1416-10-15.5 D</a>	14" x 16" x 10"	59" x 21 1/2"	<a href="#">DWDD-2-1616-10-15.5 D</a>	16" x 16" x 10"	63" x 21 1/2"
<a href="#">DWDD-2-1416-4.5-18.5 D</a>	14" x 16" x 4 1/2"	65" x 21 1/2"	<a href="#">DWDD-2-1616-4.5-18.5 D</a>	16" x 16" x 4 1/2"	69" x 21 1/2"
<a href="#">DWDD-2-1416-7.5-18.5 D</a>	14" x 16" x 7 1/2"	65" x 21 1/2"	<a href="#">DWDD-2-1616-7.5-18.5 D</a>	16" x 16" x 7 1/2"	69" x 21 1/2"
<a href="#">DWDD-2-1416-10-18.5 D</a>	14" x 16" x 10"	65" x 21 1/2"	<a href="#">DWDD-2-1616-10-18.5 D</a>	16" x 16" x 10"	69" x 21 1/2"
<a href="#">DWDD-2-1416-4.5-24.5 D</a>	14" x 16" x 4 1/2"	77" x 21 1/2"	<a href="#">DWDD-2-1616-4.5-24.5 D</a>	16" x 16" x 4 1/2"	81" x 21 1/2"
<a href="#">DWDD-2-1416-7.5-24.5 D</a>	14" x 16" x 7 1/2"	77" x 21 1/2"	<a href="#">DWDD-2-1616-7.5-24.5 D</a>	16" x 16" x 7 1/2"	81" x 21 1/2"
<a href="#">DWDD-2-1416-10-24.5 D</a>	14" x 16" x 10"	77" x 21 1/2"	<a href="#">DWDD-2-1616-10-24.5 D</a>	16" x 16" x 10"	81" x 21 1/2"

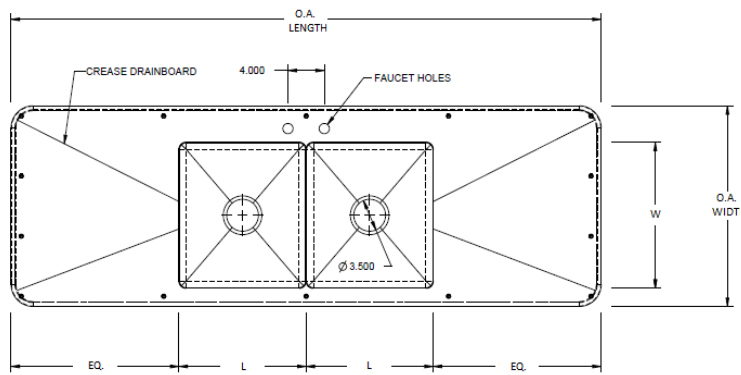

**PLAN**

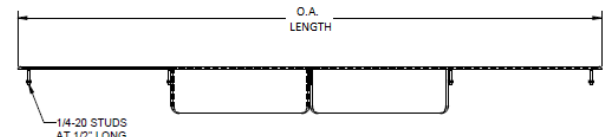

**ELEVATION**

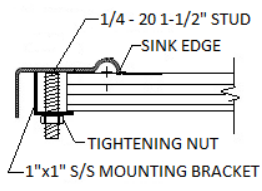

**DETAIL SECTION**

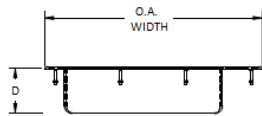

**SECTION**

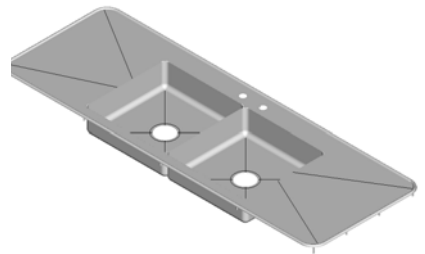

**ISOMETRIC VIEW**

**Mechanical Specifications**

- 16 gauge 304 stainless steel fabrication
- 3 1/2" drain opening with crumb cup drain and basket strainers 1 1/2" IPS
- Fully welded, seamless and polished to a #3 commercial finish
  - Horizontal and vertical corners covered to a 3/4" radius
  - Die formed depression to drain in bowl bottom
    - 1 set of faucet holes 4" o.c.
    - 1" x 1" stainless steel mounting bracket
- 1/4 - 20 studs @ 1 1/2" long welded to underside of sink edge
- Feathered edge around perimeter of sink bowl on all 4 sides
  - NSF listed and labeled

**Optional**

- 14 gauge 304 stainless steel fabrication available
  - Different bowl sizes and depths
  - Additional faucet drillings
- Sound deadening to underside of sink bowl
  - ADA options