

HAND SINKS
DH-23, DH-24, DH-25
(Including Low-Lead Faucet)

PROJECT#: _____

ITEM# _____

MODEL# _____



DH-23
*** ADA Hand Sink**

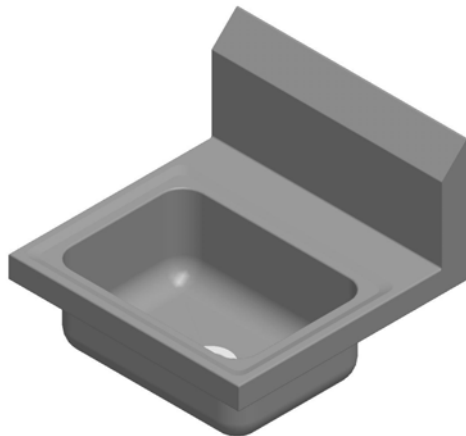

DH-24



DH-25

Low Cost Solutions for Back Room Operations:

- ◆ Supermarkets
- ◆ Convenience Stores
- ◆ Hospitals
- ◆ Factories

Features:

- ◆ Constructed from Heavy Gauge Type 304 Series Stainless Steel
- ◆ Available through the Amtekco Quick Ship Program
- ◆ All Sinks are N.S.F. Listed
- ◆ Multiple Designs for Multiple Applications

Mechanical Specifications:

- ◆ Meets “Low Lead” or “Lead-Free” Faucet Specifications
- ◆ Sink Bowl is 13-3/4” x 9-3/4” x 5-3/4”
- ◆ ADA Sink Bowl is 14” x 16” x 5-7/8”
- ◆ Crumb Cup Drain 1-1/2” NPS
- ◆ Faucets 1/2” NPS
- ◆ Refer to back of sheet for individual mechanical specifications

MODEL#	SHIPPING WEIGHT
DH-23	13 lbs.
DH-24	16 lbs.
DH-25	17 lbs.

All Models Can Be Shipped U.P.S.

Amtekco offers a full line of standard hand washing sinks to satisfy every requirement and the most rigorous local sanitation requirements. These superior products feature type 304 stainless steel throughout for long life, ease in cleaning and low maintenance. Rugged, heavy gauge, die stamped and welded construction provides for rigid wall mounting for years of trouble free use. All faucets are N.S.F. listed.

Models are in stock for immediate shipments



HAND SINKS DH-23, DH-24, DH-25 (Including Low-Lead Faucet)

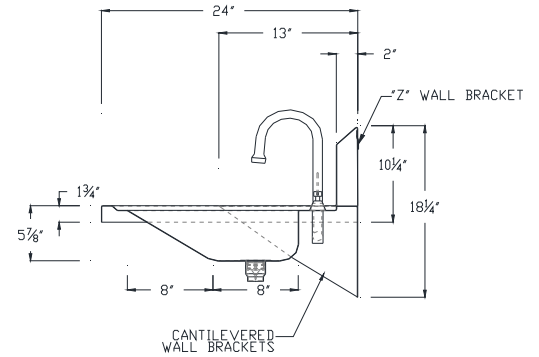
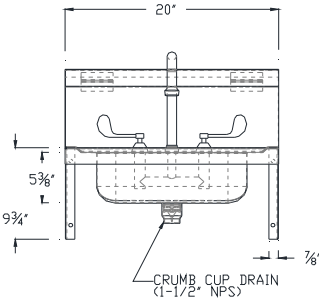
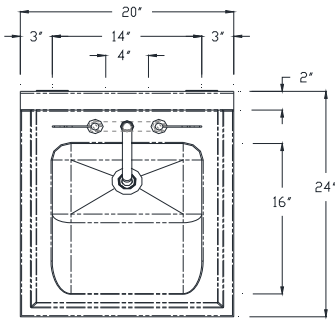

Accessories:

- ◆ Low Lead Faucet —#B-2865-06 w/ Gooseneck Spout (1/2" NPS) and Wrist Blade Handles
- ◆ Crumb Cup Drain (1-1/2" NPS)
- ◆ Cantilevered Wall Brackets

DH-23

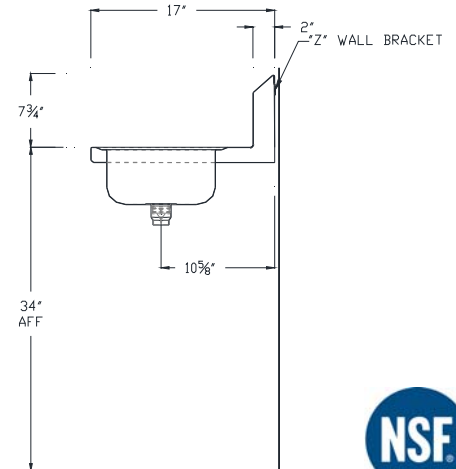
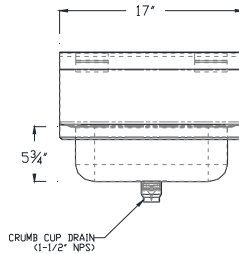
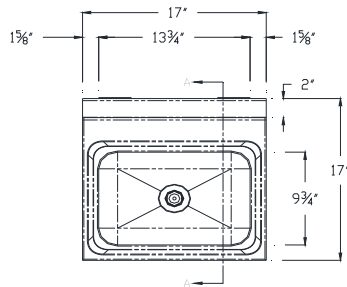

Accessories:

- ◆ Crumb Cup Drain (1-1/2" NPS)
- ◆ Wall Mounting Bracket

DH-24

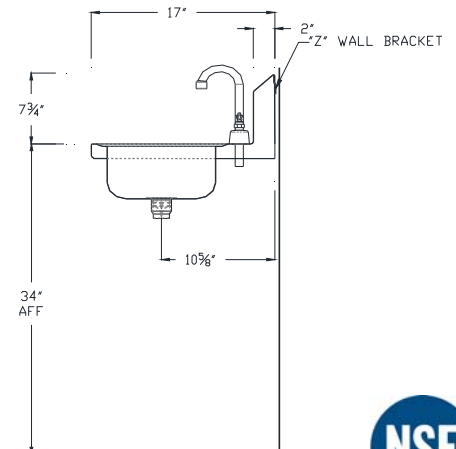
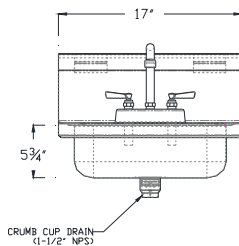
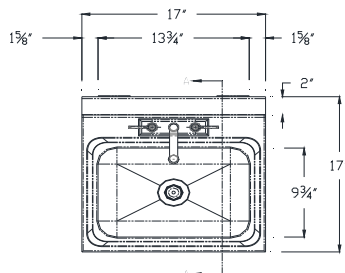

Accessories:

- ◆ Low-Lead Faucet - #KL41-4000
- ◆ Crumb Cup Drain (1-1/2" NPS)
- ◆ Wall Mounting Bracket

DH-25

